

Conext CL125 Inverter - Active and Reactive Power Control and LVRT/HVRT

976-0406-01-01/A
May 2018
Application Note

EXCLUSION FOR DOCUMENTATION
UNLESS SPECIFICALLY AGREED TO IN WRITING, SELLER
(A) MAKES NO WARRANTY AS TO THE ACCURACY, SUFFICIENCY OR SUITABILITY OF ANY TECHNICAL OR OTHER INFORMATION PROVIDED IN ITS MANUALS OR OTHER DOCUMENTATION; (B) ASSUMES NO RESPONSIBILITY OR LIABILITY FOR LOSSES, DAMAGES, COSTS OR EXPENSES, WHETHER SPECIAL, DIRECT, INDIRECT, CONSEQUENTIAL OR INCIDENTAL, WHICH MIGHT ARISE OUT OF THE USE OF SUCH INFORMATION. THE USE OF ANY SUCH INFORMATION WILL BE ENTIRELY AT THE USER'S RISK; AND (C) REMINDS YOU THAT IF THIS MANUAL IS IN ANY LANGUAGE OTHER THAN ENGLISH, ALTHOUGH STEPS HAVE BEEN TAKEN TO MAINTAIN THE ACCURACY OF THE TRANSLATION, THE ACCURACY CANNOT BE GUARANTEED. APPROVED CONTENT IS CONTAINED WITH THE ENGLISH LANGUAGE VERSION.

Objective

The goal of this application note is to describe the CL125 inverter's active/reactive power control and Low Voltage/High Voltage Ride-Through (LVRT/HVRT) methods, input parameters, and range.

DANGER

RISK OF FIRE, ELECTRIC SHOCK, EXPLOSION, AND ARC FLASH

This Application Note is in addition to, and incorporates by reference, the relevant product manuals for each product in the Conext CL125 Inverter. Before reviewing this Application Note you must read the relevant product manuals. Unless specified, information on safety, specifications, installation, and operation is as shown in the primary documentation received with the product. Ensure you are familiar with that information before proceeding.

Failure to follow these instructions will result in death or serious injury.

CL125 Active and Reactive Power Controls and Low Voltage & High Voltage Ride-Through Settings

Standards: BDEW, California Rule 21, UL1741SA

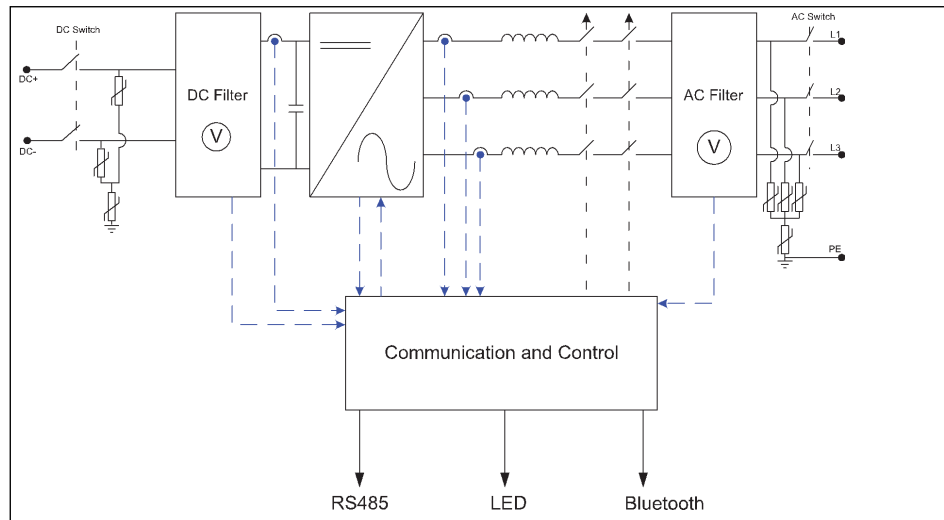

Figure 1 Block diagram of CL125 PV Inverter

Inverter power can be controlled either by Bluetooth through the eConfigure CL125 APP or remotely using RS485 Modbus.

Configurable inverter power controls are:

- Active power control (see page 3)
- Reactive power control (see page 7)
- LVRT/HVRT - low voltage ride-through/high voltage ride-through (see page 14)

Active Power Control

Actual active power that the inverter delivers is a function of the available power in the PV array, but users can set active power limit using an active power control method. This method is useful when a set limit is required for a specific application such as, zero export or to improve the overall system stability.

Active power output limit could be set by the user on the inverter using either Modbus communication signals from an external controller or the eConfigure CL125 APP using Bluetooth interface.

The inverter responds to the command within a specific time range of 500 ms to 1 second but overall response time for the event would be dependent on the method used to deliver the command. This is because its communication mechanism includes some time delay as well.

Method 1: Active Power Limit

Active power limit parameter change

Table 1 Active power limit parameter change

Parameter to change	Unit	Min	Default	Max	Resolution	Parameter Value Information
Active power limit	%	0	*	100	0.1%	Nominal power can be limited in percentage (%).
Speed control	-	-	#	--	--	Sets the change rate of active power. When ON, active power speed can be increased (ascend) or decreased (descend).
Active power ascend speed	%/min	8	*	6000	1%	Active power ascend speed rate measured in % per minute.
Active power descend speed	%/min	8	*	6000	1%	Active power descend speed rate measured in % per minute.

* - this value depends on a country-specific grid code requirement.

- this is either OFF or ON depending on a country-specific grid code requirement.

Active power ramping

When the inverter returns to the online state after a grid event, the active power may be ramped up gradually from 0% to 100% over a specified period using the **Power increase enable** parameter.

For example, if the user sets **Power increase enable** to **ON** with a **Power increase speed** of **10%/min**, then the power will rise at 10% per minute. When 100%/min power increase speed is selected, the inverter will supply full active power from the available PV power into the grid.

Table 2 Active power ramping parameter settings

Parameter to change	Unit	Min	Default	Max	Resolution	Parameter Value Information
Power increase enable	-	-	#	--	--	Sets the increase rate of active power after an event (or fault). When ON, active power speed can be increased.
Power increase speed	%/min	8	*	6000	1%	Power increase speed rate measured in % per minute.
Active setup permanent	-	-	#	--	--	When ON, active power settings are saved.

* - this value depends on a country-specific grid code requirement.

- this is either OFF or ON depending on a country-specific grid code requirement.

Time parameter change

Table 3 Time parameter settings

Parameter to change	Unit	Min	Default	Max	Resolution	Parameter Value Information
Standby Time	sec	20	20	255	1	Time from inverter standby to start up
Recovery Time	sec	0	300	900	1	Time from inverter fault clearing to standby

Method 2: Maximum Active power limit function of the frequency P(f): Derating

Frequency-based active power de-rating allows users to control the inverter's active power output with respect to change in frequency. This control method follows a defined slope based on three power and frequency values. The eConfigure CL125 APP will display these values and allow users to change them for defining the curve. When defining the values, ensure that $P1 > P2 > P3$.

Table 4 CL125 Active Power P(f) Derating parameter settings

Parameter to change	Unit	Min	Default	Max	Resolution	Parameter Value Information
Frequency derating	-	-	#	--	--	When ON, the selected inverter will operate in active power derating mode when the grid frequency exceeds the set value.
F1 F2 F3	Hz	50.00 60.00	-	55.00 65.00	0.01	These three values of frequency and power define the frequency derating curve. The user decides the slope of derating and enter the calculated values. $P1 > P2 > P3$
P1 P2 P3	%	0	*	100	1	
Frequency derating recovery point	Hz	50.00 60.00	-	55.00 65.00	0.01	

* - this value depends on a country-specific grid code requirement.

- this is either OFF or ON depending on a country-specific grid code requirement.

Method 3: Grid Voltage Active Power Parameter Setting

Output active power will derate when AC grid voltage will exceed the set value. Configuration parameters are as given below.

Table 5 CL125 Active Power P(f) Derating parameter settings

Parameter to change	Unit	Min	Default	Max	Resolution	Parameter Value Information
Voltage power adjustment	-	-	#	--	--	When ON, the selected inverter's derating voltage slope and time can be adjusted.
Derating start voltage	%	105	*	150	1	Starting voltage at which active power begins to derate.
Derating slope	%	0	*	100	1	Slope of active power in derating mode.
Derating time	s (sec)	0	*	600	1	The frequency at which active power will start to increase after a frequency derating.

* - this value depends on a country-specific grid code requirement.

- this is either OFF or ON depending on a country-specific grid code requirement.

Reactive Power Control

The inverter provides a reactive power regulation function. Use the Reactive adjusting option switch to activate this function and select the proper regulation mode as

Table 6 CL125 Regulation modes

Regulation mode	Explanation
Off	The power factor (PF) is limited to +1.000, and the "Reactive power limit" is limited to 0.0%.
Pf	The reactive power can be regulated by the parameter PF.
Qt	The reactive power can be regulated by the parameter Reactive power limit (in %).
Q(P)	The PF changes with the output power of the inverter.
Q(U)	The reactive power changes with the grid voltage.

NOTE: When one method is selected, the other methods are disabled.

Method 1: Pf-Configurable Constant Power Factor, $\cos\Phi = \cos\Phi$

The following graph for CL125 limits the selectable value for **Q** as a function of active power **P**.

$$\cos\varphi = \frac{P}{\sqrt{P^2 + Q^2}} \quad |Q| = \sqrt{S^2 - P^2}$$

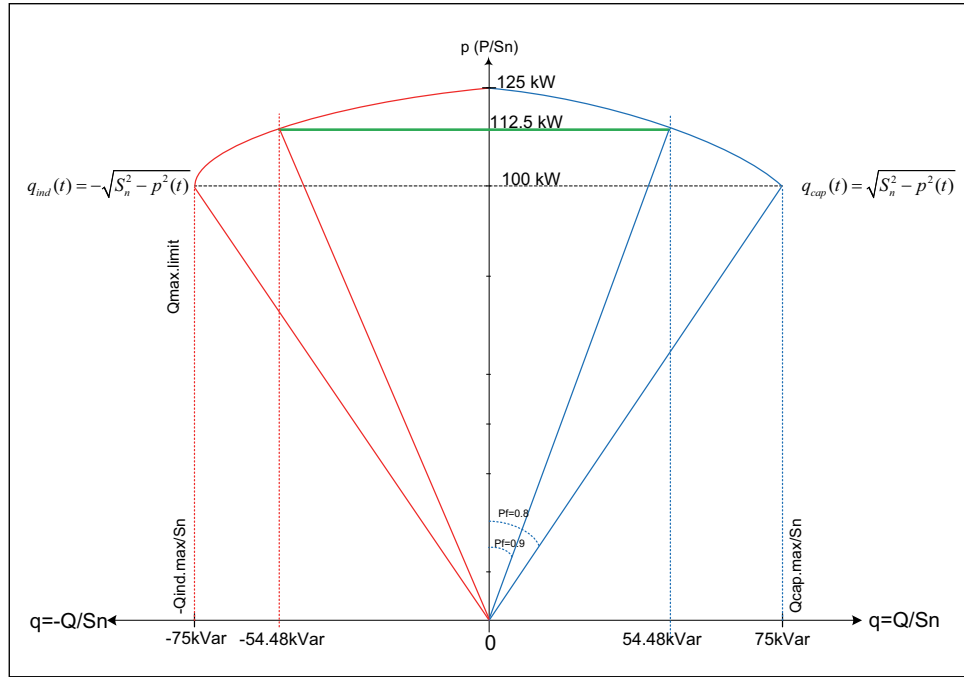

Figure 2 P-Q Curves for CL125

The graph above represents the default structure implementation.

$$\text{When } p \geq 80\% P_n \quad Q_{cap}(t) = \sqrt{S_n^2 - p^2(t)} \quad Q_{ind}(t) = \sqrt{S_n^2 - p^2(t)}$$

Table 7 Pf limits parameter settings

Parameter to change	Unit	Min	Default	Max	Resolution	Parameter Value Information
Reactive adjusting option switch	-	-	-	-	-	Select Pf

Table 7 Pf limits parameter settings

Parameter to change	Unit	Min	Default	Max	Resolution	Parameter Value Information
Power factor	-	-0.800 (ind)	*	+0.800 (cap)	0.001	Power factor of inverter AC output
Reactive Setup Permanent	-	-	#	--	--	When ON, reactive power settings are saved.

* - this value depends on a country-specific grid code requirement.

- this is either OFF or ON depending on a country-specific grid code requirement.

Method 2: Qt-Configurable Constant Reactive Power Q

The inverter delivers configured value (%) of constant reactive power **Q** when this method is selected. The corresponding value of **Q** of the selected % value would be based on Figure 7 on page 18.

Table 8 Q-Var limits parameter settings

Parameter to change	Unit	Min	Default	Max	Resolution	Parameter Value Information
Reactive adjusting option switch	-	-	-	-	-	Select Qt
Reactive power limit	%	-100	0.0	+100	1%	100% of reactive power is equal to 75kVar.
Reactive Setup Permanent	-	-	#	--	--	When ON, reactive power settings are saved.

* - this value depends on a country-specific grid code requirement.

- this is either OFF or ON depending on a country-specific grid code requirement.

Method 3: Q(P) - Configurable Power Factor Function of the Active Power, $\cos\Phi(P)$

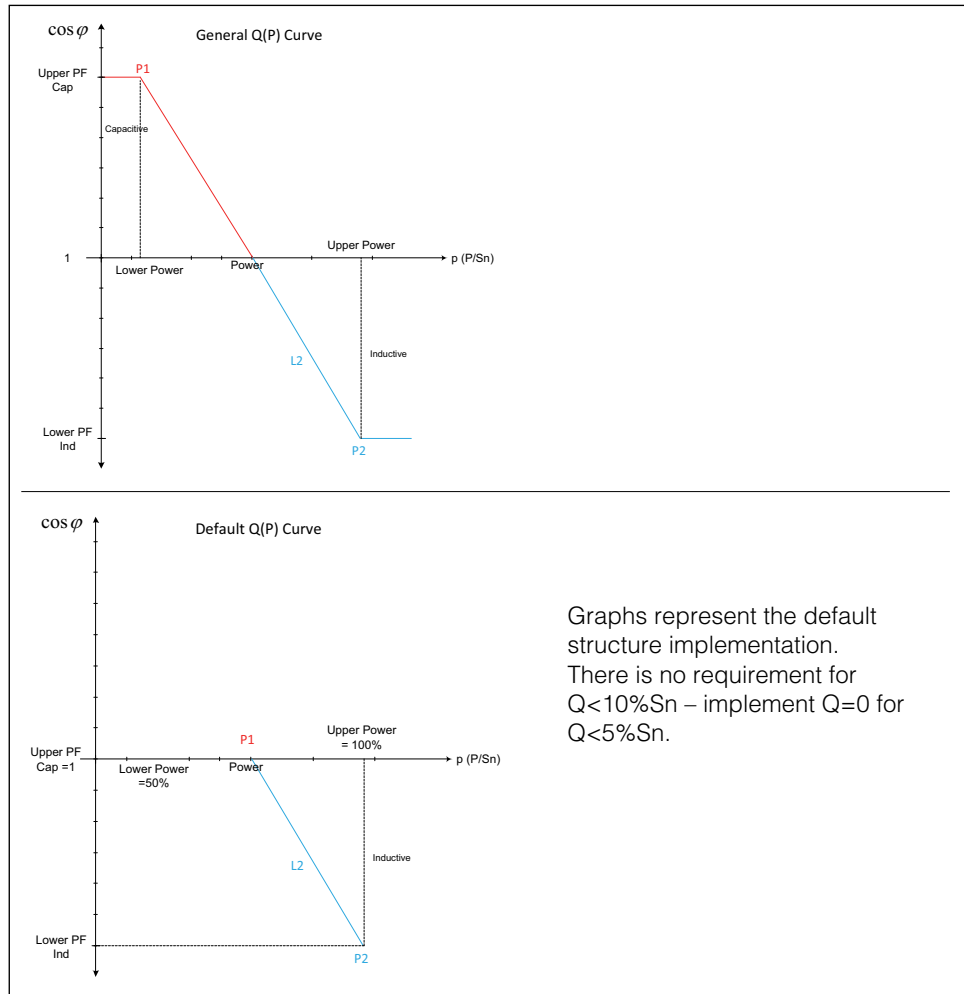

Figure 3 General and Default Q(P) curve for CL125

Table 9 Q(P) method parameter settings

Parameter to change	Unit	Min	Default	Max	Resolution	Parameter Value Information
Reactive adjusting option switch	-	-	-	-	-	Select Q(P)
Lower power	%	0	*	50	0.1%	Output power of P1 in Q(P) mode curve
Upper power	%	50	*	100	0.1%	Output power of P2 in Q(P) mode curve

Table 9 Q(P) method parameter settings

Parameter to change	Unit	Min	Default	Max	Resolution	Parameter Value Information
Upper limit - Pf(Cap)	-	0.900	*	1.000	0.001	Power factor of P1 in Q(P) mode curve
Lower limit - Pf(Ind)	-	0.900	*	1.000	0.001	Power factor of P2 in Q(P) mode curve
Reactive Setup Permanent	-	-	#	--	--	When ON, reactive power settings are saved.

* - this value depends on a country-specific grid code requirement.

- this is either OFF or ON depending on a country-specific grid code requirement.

Method 4: Q(U) - Configurable Reactive Power Function of the Grid Voltage, $Q(U_{\text{grid}})$

This method offers the change in ratio Q/Sn with respect to grid voltage.

Table 10 Q(U) method parameter settings

Parameter to change	Unit	Min	Default	Max	Resolution	Parameter Value Information
Reactive adjusting option switch	-	-	-	-	-	Select Q(U)
Lower U limit	%	80	*	100	0.1%	Grid voltage limit of P1 in Q(U) mode curve (in %)
U1 limit	%	90	*	110	0.1%	Grid voltage limit of P2 in Q(U) mode curve (in %)
U2 limit	%	100	*	110	0.1%	Grid voltage limit of P3 in Q(U) mode curve (in %)
Upper U limit	%	100	*	120	0.1%	Grid voltage limit of P4 in Q(U) mode curve (in %)

Table 10 Q(U) method parameter settings

Parameter to change	Unit	Min	Default	Max	Resolution	Parameter Value Information
Hysteresis	%	0	*	5	0.1%	Hysteresis voltage width (in %)
Lower Q/Sn	%	0	8	50	0.1%	Inductive Q/Sn value of P4 in the Q(U) mode curve (in %)
Upper Q/Sn	%	0	8	50	0.1%	Capacitive Q/Sn value of P1 in the Q(U) mode curve (in %)
Reactive Setup Permanent	-	-	--	*	--	When ON, reactive power settings are saved.

* - this value depends on a country-specific grid code requirement.

- this is either OFF or ON depending on a country-specific grid code requirement.

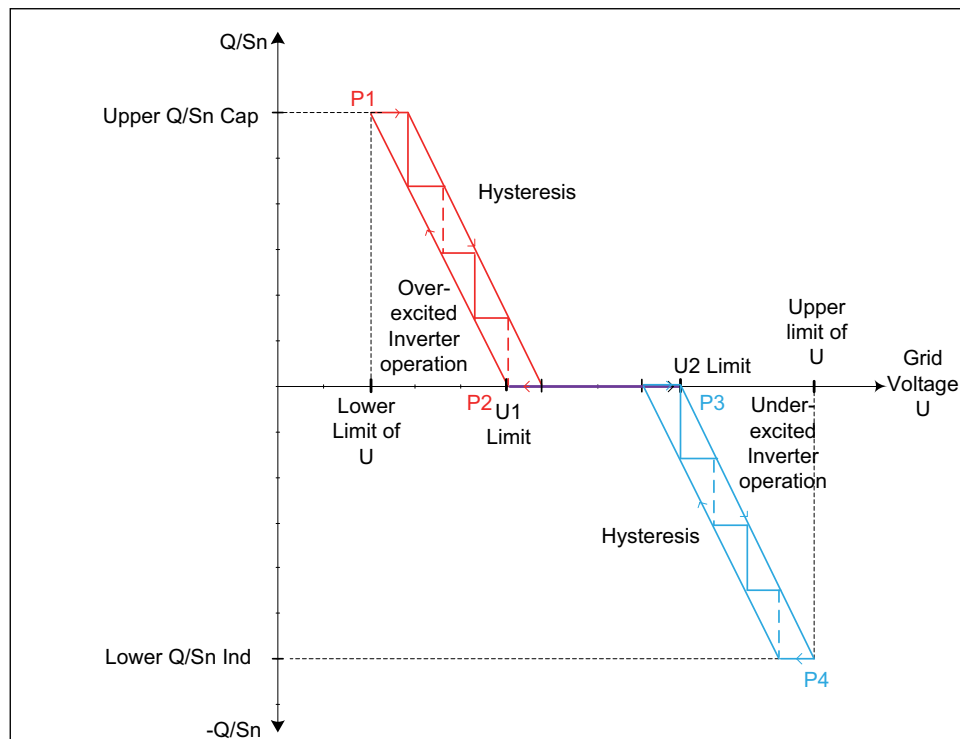

Figure 4 Q(U) settings curve for CL125

Interval 1 should be:

$$v_{ac}^{abc} < V_{acMin} \rightarrow q(v) = Q_m$$

Interval 2 should be:

$$V_{acMin} < v_{ac}^{abc} < V_{Lset} + V_{Hyst} \rightarrow q(v) = |q_{cap60}| \left(1 - \frac{v_{grid} - V_{acMin}}{V_{Lset} - V_{acMin}} \right)$$

Interval 3 should be:

$$V_{Lset} + V_{Hyst} \leq v_{ac} \leq V_{Hset} - V_{Hyst} \rightarrow q(v) = 0$$

Interval 4 should be:

$$V_{Lset} - V_{Hyst} \leq v_{ac}^{abc} \leq V_{Hset} \rightarrow q(v) = -|q_{ind60}| \left(\frac{v_{grid} - V_{acMin}}{V_{Lset} - V_{acMin}} \right)$$

Interval 5 should be:

$$V_{acMax} \leq v_{ac}^{abc} \rightarrow q(v) = Q_m$$

Convention:

1. Reactive Capacitive Power injected to grid: positive value set
2. Reactive Inductive Power injected to grid: negative value set

Low Voltage/High Voltage Ride-Through (LVRT/HVRT)

During a ride-through event, the inverter continues to operate under a defined duration of low or high grid voltage. A voltage ride-through is the capability of the inverter to maintain output current and remain online when grid voltage is temporarily outside the nominal dead band. When grid voltage drops below the preset low voltage threshold while the inverter remains online, the event is called a low voltage ride-through (LVRT). When grid voltage goes above the preset high voltage threshold while the inverter remains online, the event is called a high voltage ride-through (HVRT).

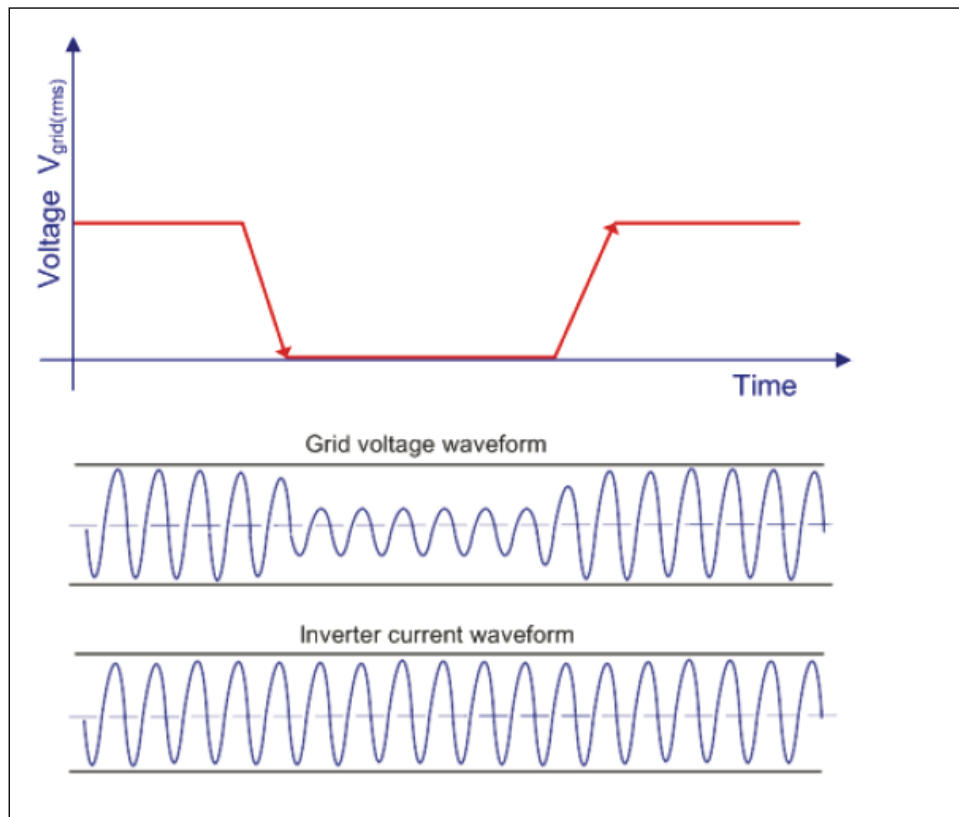

Figure 5 Voltage Ride-Through

After the voltage dip, the reactive current reference would be changed according to the country specific requirements as shown in Figure 6.

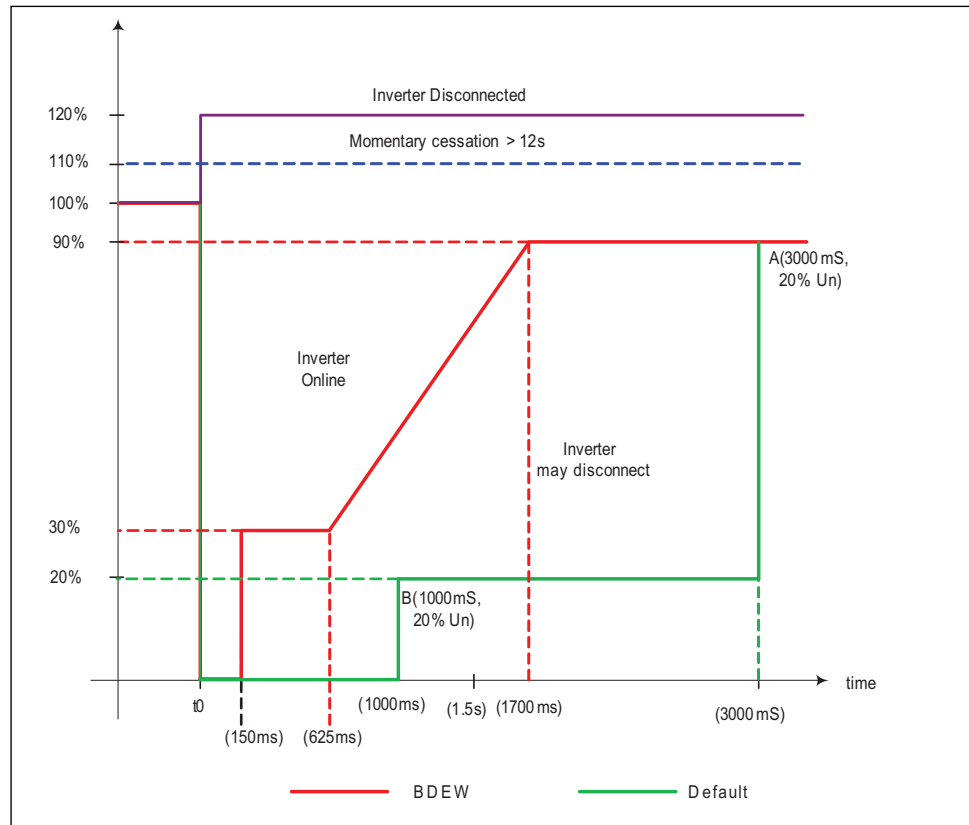

Figure 6 Low voltage/high voltage ride-through curve

Table 11 Low voltage ride through parameter settings

Parameter to change	Unit	Min	Default	Max	Resolution	Parameter Value Information
LVRT	-	-	#	--	--	When ON, the selected inverter will remain connected to the grid during event conditions and provide reactive power.
LVRT Voltage V1	V (volts)	60	*	600	0.1	User set
LVRT Voltage V2	V (volts)	60	*	600	0.1	User set
LVRT Voltage V3	V (volts)	60	*	600	0.1	User set
LVRT Voltage V4	V (volts)	60	*	600	0.1	User set

Table 11 Low voltage ride through parameter settings

Parameter to change	Unit	Min	Default	Max	Resolution	Parameter Value Information
LVRT Voltage V5	V (volts)	60	*	600	0.1	User set
LVRT T1	ms (millisec)	0	*	60000	1	User set
LVRT T2	ms (millisec)	0	*	60000	1	User set
LVRT T3	ms (millisec)	0	*	60000	1	User set
LVRT T4	ms (millisec)	0	*	60000	1	User set
LVRT T5	ms (millisec)	0	*	60000	1	User set
LVRT k factor	-	0	*	10	0.1	User set parameter for the reactive power injection calculation

* - this value depends on a country-specific grid code requirement.

- this is either OFF or ON depending on a country-specific grid code requirement.

Table 12 High voltage ride through parameter settings

Parameter to change	Unit	Min	Default	Max	Resolution	Parameter Value Information
HVRT	-	-	#	--	--	When ON, the selected inverter will remain connected to the grid during event conditions and provide reactive power.
HVRT Voltage V1	V (volts)	447	*	826	0.1	User set
HVRT Voltage V2	V (volts)	447	*	826	0.1	User set
HVRT Voltage V3	V (volts)	447	*	826	0.1	User set
HVRT Voltage V4	V (volts)	447	*	826	0.1	User set

Table 12 High voltage ride through parameter settings

Parameter to change	Unit	Min	Default	Max	Resolution	Parameter Value Information
HVRT Voltage V5	V (volts)	447	*	826	0.1	User set
HVRT T1	ms (millisec)	0	*	60000	1	User set
HVRT T2	ms (millisec)	0	*	60000	1	User set
HVRT T3	ms (millisec)	0	*	60000	1	User set
HVRT T4	ms (millisec)	0	*	60000	1	User set
HVRT T5	ms (millisec)	0	*	60000	1	User set
HVRT k factor	-	0	*2	10	0.1	User set parameter for the reactive power injection calculation

* - this value depends on a country-specific grid code requirement.

- this is either OFF or ON depending on a country-specific grid code requirement.

eConfigure CL1 25 APP Screen Flow

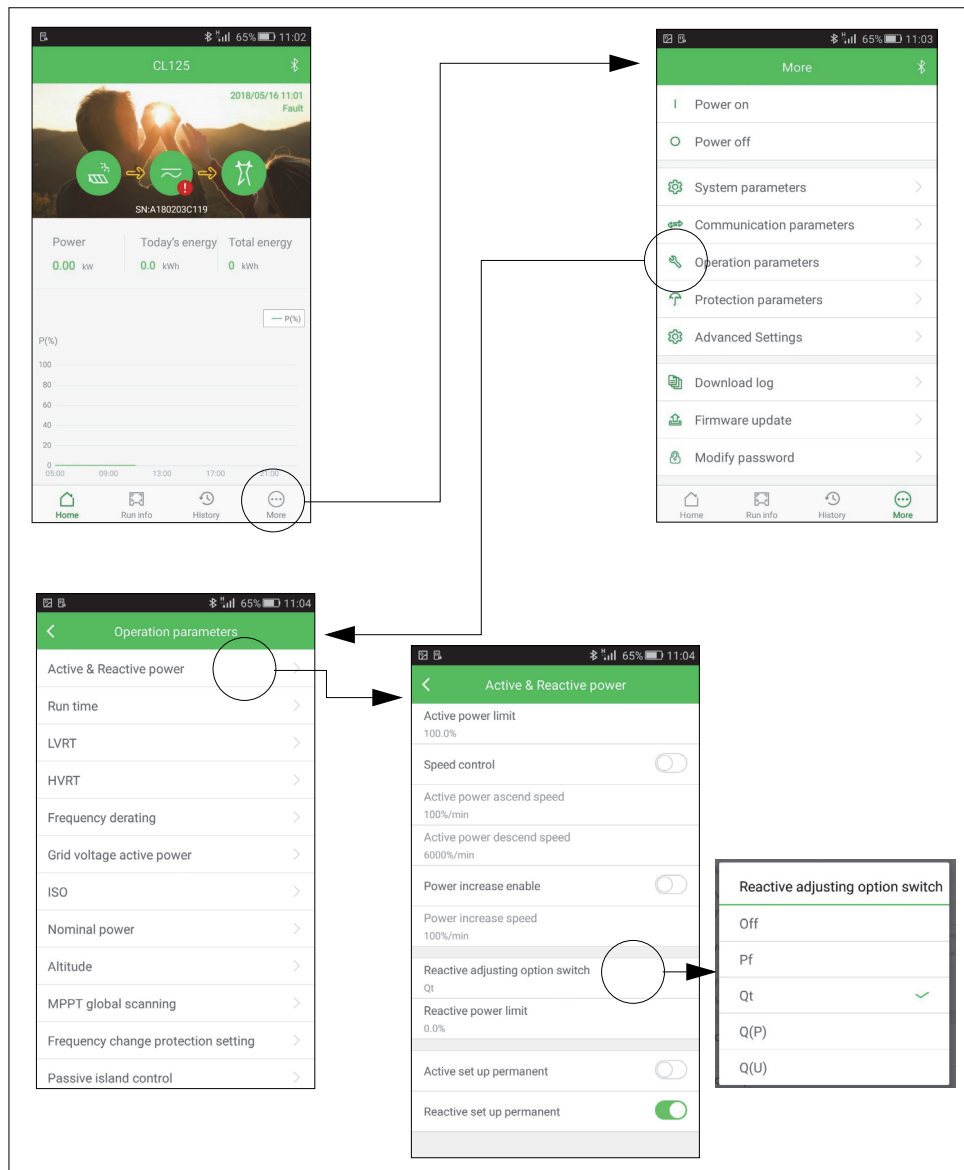

Figure 7 Various Power Control Screens from the eConfigure CL125 APP 1/2

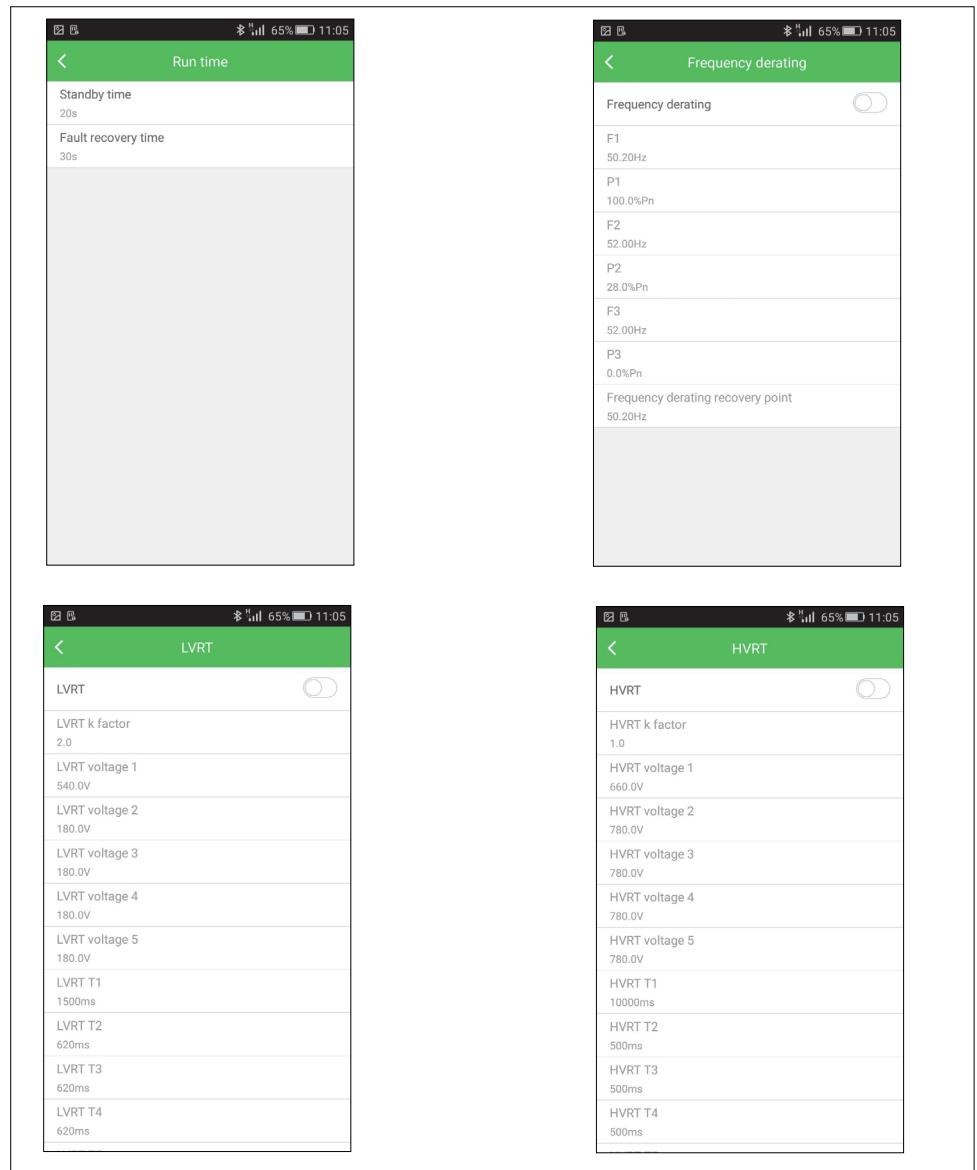

Figure 8 Various Power Control Screens from the eConfigure CL125 APP 2/2