

# Conext CL125 Inverter

Solution Guide for Decentralized PV Systems  
(For North America)

Copyright © 2018 Schneider Electric. All Rights Reserved. All trademarks are owned by Schneider Electric Industries SAS or its affiliated companies.

### **Exclusion for Documentation**

UNLESS SPECIFICALLY AGREED TO IN WRITING, SELLER

(A) MAKES NO WARRANTY AS TO THE ACCURACY, SUFFICIENCY OR SUITABILITY OF ANY TECHNICAL OR OTHER INFORMATION PROVIDED IN ITS MANUALS OR OTHER DOCUMENTATION;

(B) ASSUMES NO RESPONSIBILITY OR LIABILITY FOR LOSSES, DAMAGES, COSTS OR EXPENSES, WHETHER SPECIAL, DIRECT, INDIRECT, CONSEQUENTIAL OR INCIDENTAL, WHICH MIGHT ARISE OUT OF THE USE OF SUCH INFORMATION. THE USE OF ANY SUCH INFORMATION WILL BE ENTIRELY AT THE USER'S RISK; AND

(C) REMINDS YOU THAT IF THIS MANUAL IS IN ANY LANGUAGE OTHER THAN ENGLISH, ALTHOUGH STEPS HAVE BEEN TAKEN TO MAINTAIN THE ACCURACY OF THE TRANSLATION, THE ACCURACY CANNOT BE GUARANTEED. APPROVED CONTENT IS CONTAINED WITH THE ENGLISH LANGUAGE VERSION WHICH IS POSTED AT [SOLAR.SCHNEIDER-ELECTRIC.COM](http://solar.schneider-electric.com).

**Document Number:** 975-0798-01-01

**Revision:** Revision A

**Date:** May 2018

**Product Part Number:** PVSCL125A

**Contact Information** <http://solar.schneider-electric.com>

Please contact your local Schneider Electric Sales Representative at: <http://solar.schneider-electric.com>

# About This Guide

## Purpose

The purpose of this Solution Guide is to provide explanations for designing a decentralized PV system using Conext CL125A String Inverters and Balance of System (BOS) components. It describes the interfaces required to implement this architecture and gives rules to design the solution.

## Scope

This Guide provides technical information and balance of system design recommendations. It explains the design requirements of each of the system components and provides details on how to choose the correct recommendations.

The information provided in this guide does not modify, replace, or waive any instruction or recommendations described in the product Installation and Owner's Guides including warranties of Schneider Electric products. Always consult the Installation and Owner's guides of a Schneider Electric product when installing and using that product in a decentralized PV system design using Conext CL inverters.

For help in designing a PV power plant, contact your Schneider Electric Sales Representative or visit the Schneider Electric website for more information at [solar.schneider-electric.com](http://solar.schneider-electric.com).

## Audience

The Guide is intended for system integrators or engineers who plan to design a De-centralized PV system using Schneider Electric Conext CL125 Inverters and other Schneider Electric equipment.

The information in this Solution Guide is intended for qualified personnel. Qualified personnel have training, knowledge, and experience in:

- Analyzing application needs and designing PV Decentralized Systems with transformer-less string inverters.
- Installing electrical equipment and PV power systems (up to 1500 V).
- Applying all applicable local and international installation codes.
- Analyzing and reducing the hazards involved in performing electrical work.
- Selecting and using Personal Protective Equipment (PPE).

## Organization

This Guide is organized into seven chapters.

Chapter 1, Introduction

Chapter 2, Decentralized PV Solutions

Chapter 3, DC System Design

Chapter 4, AC System Design

Chapter 5, Important Aspects of a Decentralized System Design

Chapter 6, Layout Optimization

Chapter 7, Frequently Asked Questions (FAQ)

### **Related Information**

You can find more information about Schneider Electric, as well as its products and services at [solar.schneider-electric.com](http://solar.schneider-electric.com).

# Important Safety Instructions

## READ AND SAVE THESE INSTRUCTIONS - DO NOT DISCARD

This document contains important safety instructions that must be followed during installation procedures (if applicable). **Read and keep this Solution Guide for future reference.**

Read these instructions carefully and look at the equipment (if applicable) to become familiar with the device before trying to install, operate, service or maintain it. The following special messages may appear throughout this bulletin or on the equipment to warn of potential hazards or to call attention to information that clarifies or simplifies a procedure.



The addition of either symbol to a “Danger” or “Warning” safety label indicates that an electrical hazard exists which will result in personal injury if the instructions are not followed.



This is the safety alert symbol. It is used to alert you to potential personal injury hazards. Obey all safety messages that follow this symbol to avoid possible injury or death.

### **DANGER**

DANGER indicates an imminently hazardous situation, which, if not avoided, will result in death or serious injury.

### **WARNING**

WARNING indicates a potentially hazardous situation, which, if not avoided, can result in death or serious injury.

### **CAUTION**

CAUTION indicates a potentially hazardous situation, which, if not avoided, can result in moderate or minor injury.

### **NOTICE**

NOTICE indicates important information that you need to read carefully.

**⚠ DANGER**

**RISK OF FIRE, ELECTRIC SHOCK, EXPLOSION, AND ARC FLASH**

This Solution Guide is in addition to, and incorporates by reference, the relevant product manuals for the Conext CL125 Inverter. Before reviewing this Solution Guide you must read the relevant product manuals. Unless specified, information on safety, specifications, installation, and operation is as shown in the primary documentation received with the products. Ensure you are familiar with that information before proceeding.

**Failure to follow these instructions will result in death or serious injury.**

**⚠ DANGER**

**ELECTRICAL SHOCK AND FIRE HAZARD**

Installation including wiring must be done by qualified personnel to ensure compliance with all applicable installation and electrical codes including relevant local, regional, and national regulations. Installation instructions are not covered in this Solution Guide but are included in the relevant product manuals for the Conext CL125 Inverter. Those instructions are provided for use by qualified installers only.

**Failure to follow these instructions will result in death or serious injury.**

# Contents

## Important Safety Instructions

### 1 Introduction

Decentralized Photovoltaic (PV) Architecture	1-2
About the Conext CL125 Inverter	1-3
Key Specifications of the Conext CL Inverter	1-4
Key Features of Integrated Wiring Compartment	1-4

### 2 Decentralized PV Solutions

Why Use Decentralized PV Solutions?	2-2
Drivers for decentralizing system design	2-2
PV System Modeling	2-3
PV System Design Using Conext CL125 Inverters	2-3
Building Blocks of a Decentralized PV System	2-4
Positioning Inverters	2-6
Inverter location	2-6
Option 1 (Inverters installed next to PV modules with first level AC Combiners)	2-7
Option 2 (Inverters installed next to AC combiner groups)	2-8
Option 3 (Inverters installed next to PV modules without first-level AC combiners)	2-9
Option 4 (Inverters installed next to LV/MV transformer)	2-10

### 3 DC System Design

DC System Design	3-2
String and Array Sizing Rules	3-2
Definitions	3-3
Use Case Example	3-4
Minimum Number of PV Modules	3-5
Maximum Number of PV Modules	3-5
Number of Strings in Parallel	3-7

### 4 AC System Design

AC System Design	4-2
AC Component Design	4-3
AC Conductor sizing	4-3
AC Combiner Box	4-4
Function	4-5
Typical use	4-5
AC Re-combiner Box	4-12
Function	4-18
Typical use	4-18
Recommended System Design	4-19

**5 Important Aspects of a Decentralized System Design**

Grounding System Design for Decentralized PV systems ----- 5-2  
    General Understanding of Grounding ----- 5-2  
    Transformer selection for decentralized PV plants with Conext CL ----- 5-5  
    Monitoring System Design ----- 5-6  
Grid Connection ----- 5-8  
Role of Circuit Impedance in Parallel Operation of Multiple Conext CL String Inverters ----- 5-8

**6 Layout Optimization**

Layout Design Rules ----- 6-2

**7 Frequently Asked Questions (FAQ)**

Safety Information ----- 7-2  
Frequently Asked Questions ----- 7-2



# Figures

Figure 1-1	Conext CL125 Inverter	1-3
Figure 1-2	Typical PV grid-tied installation using Conext CL inverters	1-3
Figure 2-1	Standard block option 1	2-7
Figure 2-2	Standard block option 2	2-8
Figure 2-3	Standard block option 3	2-9
Figure 2-4	Standard block Option 4	2-10
Figure 3-1	Typical DC Combiner circuit diagram of CL Inverter	3-8
Figure 3-2	Y-type connectors with in-line 15A fuse	3-8
Figure 4-1	Type 3R AC combiner box enclosure	4-4
Figure 4-2	AC combiner panelboard options	4-8
Figure 4-3	Recommended type of HCN for AC combiner panel	4-8
Figure 4-4	AC combiner - HCN panelboard trims and options (with main CB or MLO)	4-9
Figure 4-5	H frame circuit breaker (125-150A) for AC combiner panel	4-9
Figure 4-6	I-Line Surgeologic TVSS Ubl	4-10
Figure 4-7	I-Line plug-on unit with Surgelogic TVSS	4-11
Figure 4-8	AC re-combiner box	4-12
Figure 4-9	Main device (MCCB/Masterpact NW / Fuse) rating table for AC re-combiner	4-15
Figure 4-10	AC re-combiner size details (option specific)	4-16
Figure 4-11	Distribution section options for QED-2 type AC re-combiner	4-16
Figure 4-12	QED-2 type AC re-combiner distribution section sizes (type specific)	4-17
Figure 4-13	Width options for distribution sections of QED-2 AC re-combiner	4-17
Figure 4-14	Expected size for single row distribution section	4-18
Figure 5-1	Grounding circuit connections	5-4
Figure 5-2	Multiple inverter parallel connection to a transformer secondary winding	5-5
Figure 5-3	CL125A communication port and termination resistor details	5-6
Figure 5-4	Generic AC grid connected inverters diagram	5-9



# Tables

Table 2-1	Decentralized PV system blocks -----	2-4
Table 3-1	NEC 690.7 voltage correction factors-----	3-6
Table 3-2	Example of highest string sizing ratios -----	3-7
Table 3-3	Conext CL125 Inverter suggested DC oversizing range -----	3-7
Table 4-1	Percentage losses for Cu cable w.r.t maximum AC cable length -----	4-4
Table 4-2	SurgeLogic TVSS branch unit options -----	4-11
Table 5-1	Power loss values for transformer ratings and impedance -----	5-6



# 1

## Introduction

This introduction chapter contains information:

- About the Conext CL125 Inverter
- Decentralized Photovoltaic (PV) Architecture
- Key Specifications of the Conext CL Inverter
- Key Features of Integrated Wiring Compartment

## Decentralized Photovoltaic (PV) Architecture

### Use of a decentralized PV Architecture

Fundamentally, decentralized PV systems are designed by locating small power inverters in a decentralized manner on the PV field area, in the vicinity of PV modules to allow for connection of the strings as simply as possible.

Advantages of a decentralized PV architecture include:

- Easy adaptation of the solution to roof or plant specificities
- Easy installation of the inverters on roof or plant
- Easy electrical protection
- Easy connection to the grid
- Easy monitoring
- Easy system maintenance
- Greater energy production

### Use of a Three Phase String Conext CL125 Inverter

The new Conext CL125A (UL) grid-tie, three-phase, string inverters are designed for outdoor installation and are the ideal solution for decentralized power plants in multiple megawatt (MW) ranges. With high-power density, market-leading power conversion efficiency and wide input range Maximum Power Point Trackers (MPPTs), these inverters are ideally suited for large scale PV plants.

### **⚠ WARNING**

#### **ELECTRICAL SHOCK HAZARD**

- The Conext CL125 Inverters are 3-phase, grid tie, transformer-less inverters, suited for use with PV modules that do not require the grounding of a DC polarity.
- Always refer to national and local installation and electrical codes when designing a power system. For both PV and AC side, the NEC guidelines (in the US) and, the CSA (in Canada) regulate the system design requirements. Additionally, installers should refer to the local installation code for the respective state or province.

**Failure to follow these instruction can result in death or serious injury.**

### Federal Communications Commission (FCC)

This equipment has been tested and found to comply with the limits for a Class A digital device, pursuant to part 15 of the FCC Rules. These limits are designed to provide reasonable protection against harmful interference when the equipment is operated in a commercial environment. This equipment generates, uses, and can radiate radio frequency energy and, if not installed and used in accordance with the instruction manual, may cause harmful interference to radio communications. Operation of this equipment in a residential area is likely to cause harmful interference, in which case the user will be required to correct the interference at his own expense.

## About the Conext CL125 Inverter

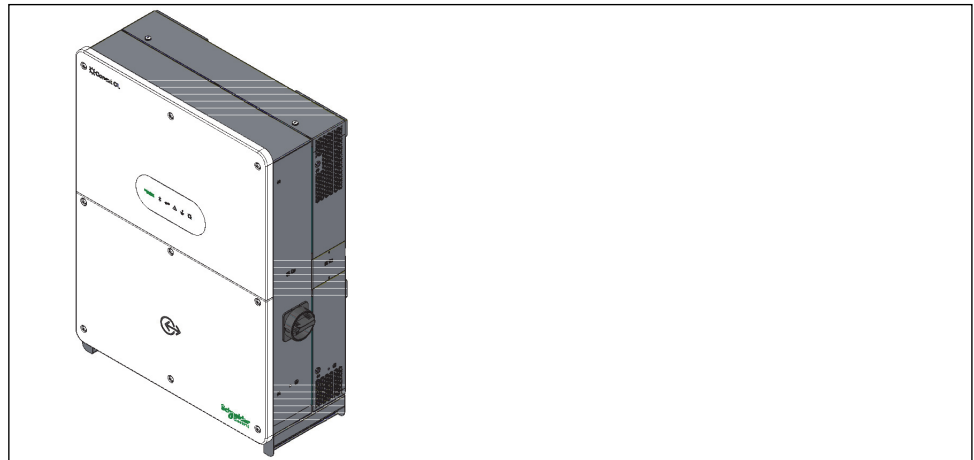

**Figure 1-1** Conext CL125 Inverter

The Conext CL Inverter is a three-phase, transformer-less, string inverter designed for high efficiency, easy installation, and maximum yield.

The inverter is designed to collect maximum available energy from the PV array by constantly adjusting its output power to track the maximum power point (MPP) of the PV array. The CL Inverter has a single MPPT channel as it is designed to be used in large scale PV plants with uniform strings.

The CL Inverter's DC input side accommodates PV arrays with open circuit voltages of up to 1500 VDC. It has a single pair of PV input terminals with direct connection from an external PV combiner box. The terminals can accept cables with a maximum size of 200 mm<sup>2</sup> (400 kcmil).

The CL Inverter has a single stage transformer-less design. Therefore, it has no galvanic isolation. It is light-weight, efficient, and has high power density suitable for large scale PV plants.

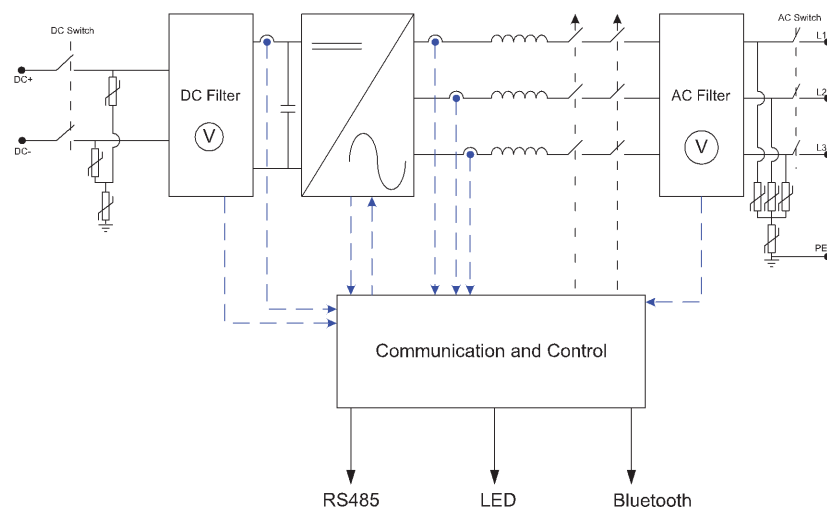

**Figure 1-2** Typical PV grid-tied installation using Conext CL inverters

## Key Specifications of the Conext CL Inverter

- Conext CL125A inverter: 125 kVA, 125kW (1500 VDC systems)
- PV compatibility: Designed to work with 1500V floating PV systems
- 600V, Three-phase STAR or DELTA type AC wiring output(3P+PE)
- Operating voltage – 860V-1450V
- Full Power MPPT voltage – 860V-1250V
- Supports high DC/AC over-paneling ratio (up to 1.5)
- Energy harvest (MPPT) efficiency: >99% (static-99.5% & Dynamic-99%)
- CEC efficiency 98.5%
- Maximum power conversion efficiency: ~98.8%
- Power factor adjustment range: 0.8 capacitive to 0.8 inductive
- Low AC output current distortion (THD < 3%) @ nominal power
- Type 4X (electronics) protection class for installation in outdoor environments
- -13 to 140 °F Operating temperature range
- Single PV Input
- RS485-Modbus, Communication protocol - Sun Spec compatible & certified
- eConfigure CL125 APP and Conext CL EasyConfig tool for local firmware upgrade and configuration

## Key Features of Integrated Wiring Compartment

- Integrated AC switch
- Integrated DC switch.
- AC Terminals with 3Phase +PE
- AC terminals with screw type (Max. 185 mm<sup>2</sup>/350kcmil, cu or AL)
- DC terminals with screw type (Max. 200 mm<sup>2</sup>/400kcmil, cu or AL)
- Type 2 AC (PCB mounted) and Type 2 DC (Modular) Surge Protection (SPD)



# 2

## Decentralized PV Solutions

This chapter on decentralized PV solutions contains the following information.

- Drivers for decentralizing system design
- Easy configuration and firmware upgrade tool such as the eConfigure CL125 APP
- PV System Modeling
- PV System Design Using Conext CL125 Inverters
- Building Blocks of a Decentralized PV System
- Inverter location

## Why Use Decentralized PV Solutions?

### Drivers for decentralizing system design

1. Lower cost of installation and easy to install
  - Smaller units have lighter weight and are easier to handle
  - Inverters can be mounted directly on/underneath the photovoltaic (PV) mounting structures
  - Product is easy and inexpensive to ship and can be installed without heavy and expensive cranes
  - No concrete mounting pad required: unit is mounted directly to wall, pole or PV module racking
2. Easy to service and increased energy harvest
  - If the inverter detects a failure event, only part of the field is affected versus a large portion of the field when a large central inverter is used, which means minimal down-time and greater return on investment (ROI)
  - High efficiency for greater harvest
3. Easy electrical protection
  - DC circuit length reduces up to the racks with short runs up to the inverters next to the PV panel strings
  - AC circuit is enlarged, requiring additional AC equipment which is typically less expensive and more readily available
  - Fire situation management is simplified and fireman safety is improved
4. Easy adaptation to PV plant layout
  - De-centralized approach covers more area of the plant
  - Tracker or Fixt mounts – smaller PV inverters bring more flexibility
5. Easy connection to the grid
  - CL125A offers connectivity to both 3-wire WYE or DELTA type windings
  - Multiple Inverters (up to 20) could be paralleled to a single transformer
6. Easy monitoring and configuration
  - Modbus RS485 daisy chain capability
  - Monitoring ready with major third-party service providers
  - Easy configuration and firmware upgrade tool such as the eConfigure CL125 APP

## PV System Modeling

Important aspects to consider for PV system modeling are:

- Site
- Type of system
- Losses

### Site

It is important to interpret site conditions carefully and model the exact conditions in PV system design software. These conditions include shadow from surroundings, ground slope, layout boundary conditions, rain water catchment area, PV module string arrangements, shape of the layout, obstacles like power lines, gas pipelines, rivers, archaeological conditions, and similar obstacles.

Once all possible factors affecting the PV system design are listed and assessed, the capacity of the selected PV installation site can be determined for further processing. Government agency permits and statutory clearances also depend on these factors. Cost of the land and the overall PV system varies with respect to these conditions.

### System

PV system installation can be grid tied, stand alone, or hybrid. It could be ground-mounted with tracking option.

Quantity and usage of generated electricity is a very important factor for deciding on the type of system. A good system design has high efficiency, flexibility and a modular approach for faster and quicker installations. When designing large-scale PV power plants, the most attention should be spent on the response of the PV plant power output against dynamic conditions of the grid. Faster power curtailment or fault ride through capability of the Inverter is useful for this purpose.

Selection of major components like PV modules, inverters and mounting structures comprises the majority of system modelling and design. These three components also affect the cost, output, and efficiency of the system.

### Losses

Any PV system has two major types of losses. Losses associated with meteorological factors and losses due to system components.

A carefully modelled PV system represents both types of losses accurately and realistically. PV system modelling should take care of each aspect of design and component to simulate the scenario that represents the actual conditions very closely.

## PV System Design Using Conext CL125 Inverters

For easy access, the Conext CL inverter's latest datasheet and system component file (.OND file) is available with widely-used modeling software (PV syst) and databases. These files are also available for download on the Schneider Electric solar web portal.

When designing standard blocks, consider the following points. This Solution Guide will help to design DC and AC electrical components of balance for systems based on these points.

- Overall system impedance (Grid + Transformer + Cables) for parallel operation of inverters
- Voltage drop between Inverter and Point of connection to grid
- Inverter's response time to grid instability or faults (Active and Reactive power curtailments and Low and High Voltage Ride Through (LVRT and HVRT))
- Design of control and monitoring architecture

Large scale ground mount systems can be modeled and designed using standard system blocks comprising of Conext CL125 Inverters and user-defined PV modules and mounting solution.

A block of 2500kW (20 x 125) for ground mount solutions can be considered to multiply several times to achieve the required capacity. A standard block is designed once for all respective components and repeated several times in the installation. It reduces the effort and time required to design the complete solution and increases the flexibility and speed of construction. Manufacturing of components also becomes quicker as a standard block uses the available ratings of components and equipment. Ultimately, the overall design results in an optimized and reliable solution from all perspectives.

## Building Blocks of a Decentralized PV System

For a modular design approach, we recommend following solution bricks or building blocks to design a decentralized PV power plant using Conext CL125 Inverters.

**Table 2-1** Decentralized PV system blocks

Brick	Description	Model	Supplier
Inverters	Conext CL125A	PVSCL125A	Schneider Electric
AC combiner box (4 inputs)	AC circuit breaker	150A	Schneider Electric
	AC Panel	I-Line series	Schneider Electric
	Surge protection device (optional)	----	External
AC recombiner box (5 inputs)	AC circuit breaker	Powerpact P & R Frame	Schneider Electric
	AC Panel	QED-2 series	Schneider Electric
	Surge protection device (optional)	I-Line SPD	Schneider Electric
Transformer	LV-MV Dy11, DY1 or DD0 Oil cooled / Dry type transformer	2500kVA, Oil immersed or Dry type, Z < 6%, 600V-3 wire WYE Secondary	Schneider Electric

**Table 2-1** Decentralized PV system blocks

DC solar PV cables	DC UV protected cables	---	External
AC cables	AC LV and MV cables	---	External
Communication and monitoring system	Complete third-party solution	---	3rd-party monitoring from: Solar Log Also Energy Enerwise
DC combiner box	DC combiner box with Type 2 protection	---	Recommended 3rd-party solution from Solar Bos

## Positioning Inverters

### **DANGER**

#### **ELECTRICAL SHOCK AND FIRE HAZARD**

Installation including wiring must be done by qualified personnel to ensure compliance with all applicable installation and electrical codes including relevant local, regional, and national regulations. Installation instructions are not covered in this Solution Guide but are included in the relevant product manuals for the Conext CL125 Inverter. Those instructions are provided for use by qualified installers only.

**Failure to follow these instructions will result in death or serious injury.**

## Inverter location

PV system design with Conext CL125A string inverters emphasizes the location of the inverter in the complete solution. The balance of the system components and the inverter wiring box model might change depending on the location of the inverters and the length of the power cables connecting them with the AC combiners and re-combiners.

We propose four types of standard design blocks to fit almost all types of installations. Each option has advantages and disadvantages with respect to other installations but, for each instance, the respective option serves the purpose in the most efficient manner.

1. Inverters installed next to PV modules
2. Inverters installed next to the AC combiner
3. Inverters installed next to PV modules without first-level AC combiners
4. Inverters installed next to LV/MV transformer

---

**NOTE:** Architecture option 1 and option 4 are recommended for the CL125A inverter.

---

### Option 1 (Inverters installed next to PV modules with first level AC Combiners)

Inverters located on the PV field “electrically” grouped in AC combiner box on the field – Inverters mounted on the PV panel structures and intermediate AC paralleling.

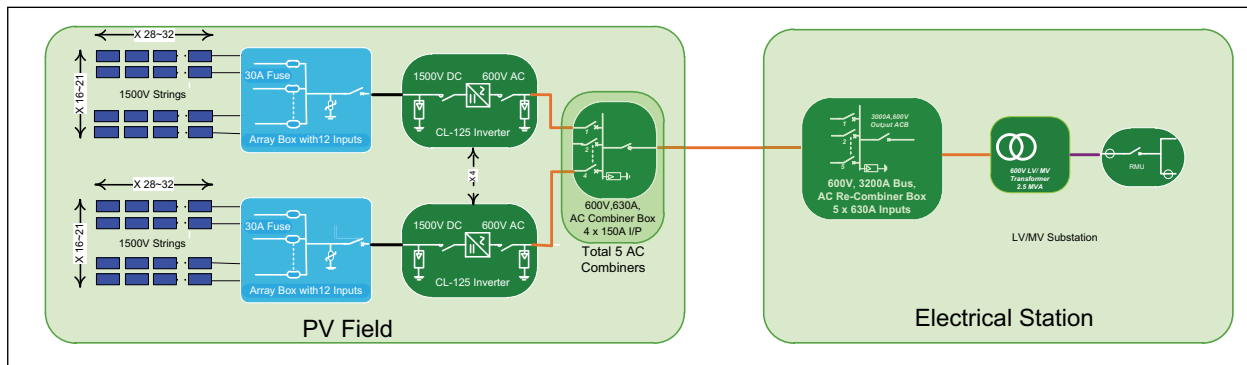

Figure 2-1 Standard block option 1

#### Advantages

- Fewer DC string cables
- Fewer DC  $I^2R$  losses
- High Flexibility
- No need of dedicated structure for Inverter mounting
- Inverters close to PV modules reducing electrified portion of system during fault
- Covers most of the usable space within boundary
- Schneider NSX160 type of breakers can be used in AC combiners – up to 4 inverters
- Integrated AC switch in CL125A inverter eliminates the requirement of external AC switch immediately after inverter

#### Disadvantages

- Longer AC cables from Inverter to first level of AC combiners
- Higher AC cable losses

## Option 2 (Inverters installed next to AC combiner groups)

Inverters grouped on the field by clusters “electrically” grouped in AC combiner box on the field – Inverters mounted on dedicated structures connected to intermediate AC combiners

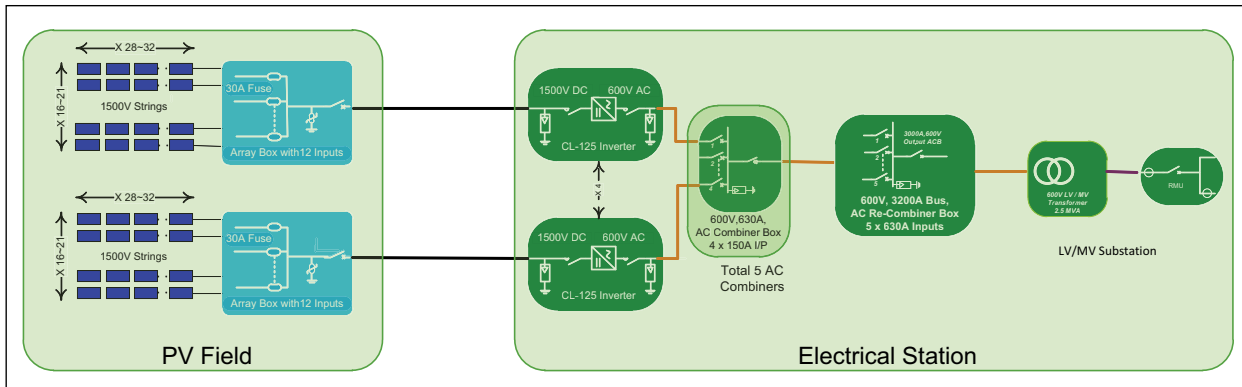

Figure 2-2 Standard block option 2

### Advantages

- Shorter AC cables
- High Flexibility
- Additional Type 2 AC SPD not required if considered in AC combiner box
- Schneider NSX160 type of breakers can be used in AC combiners – up to 4 inverters

### Disadvantages

- Longer DC string cables length might need higher size (cross section) of DC cable
- Dedicated structures required for Inverter and AC combiner mounting
- Higher DC cable losses



### Option 3 (Inverters installed next to PV modules without first-level AC combiners)

Inverters spread on the field – Inverters mounted on PV panel structures and AC paralleling in MV stations.

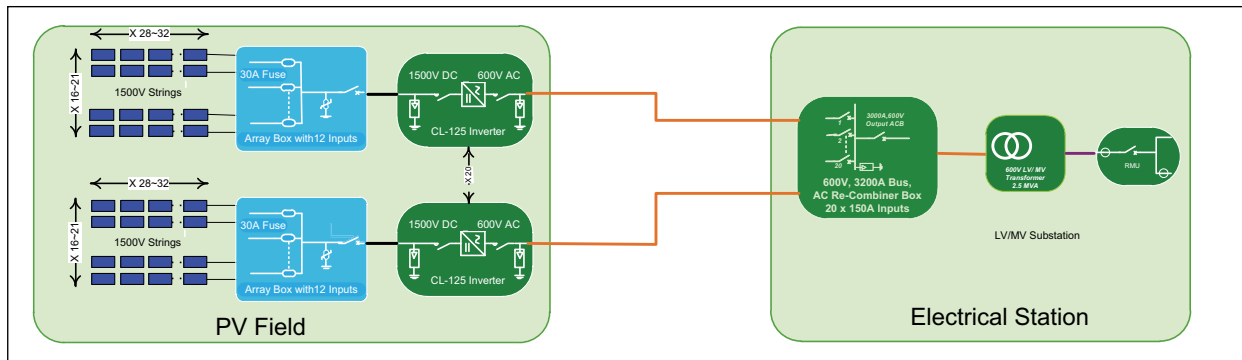

Figure 2-3 Standard block option 3

#### Advantages

- Fewer DC string cables
- Fewer DC  $I^2R$  losses
- High Flexibility
- No need of dedicated structure for Inverter mounting
- Inverters close to PV modules reducing electrified portion of system during fault
- Covers most of the usable space within boundary
- First level AC combiners avoided resulting in cost savings

#### Disadvantages

- longer AC cables from Inverter to AC combiners
- High AC cable losses
- Increased size of AC cable will require higher size of terminal blocks in external AC combiner boxes
- High number of AC cables run from inverter to MV stations with increased time and chances of connection mistakes
- May need to use a Residual Current Monitoring (RCM) unit

### Option 4 (Inverters installed next to LV/MV transformer)

DC distribution – Inverters close to LV/MV substation on a dedicated structure and AC paralleling in LV/MV substation.

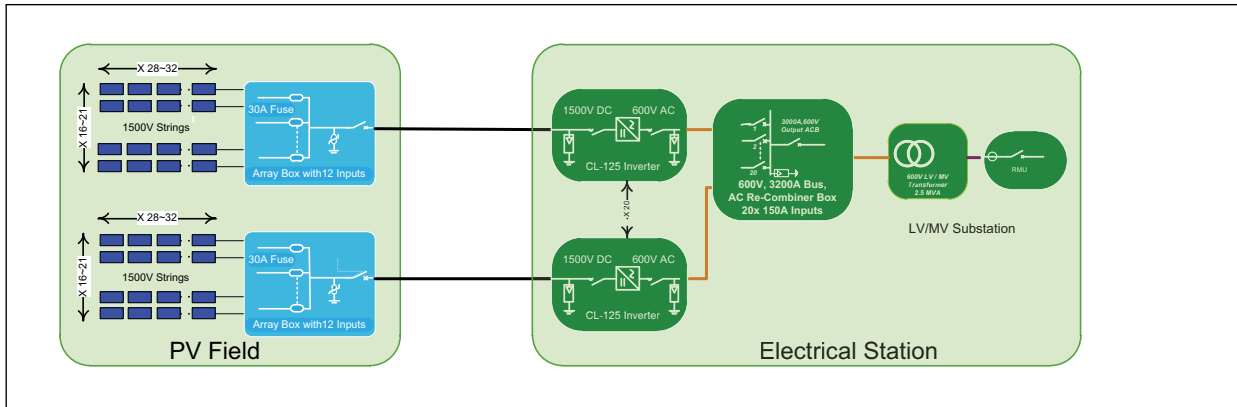

Figure 2-4 Standard block Option 4

#### Advantages

- Shorter AC cables
- High Flexibility
- AC SPD not required if considered in AC combiner box
- Easy access to Inverters for service and maintenance
- RCD not required

#### Disadvantages

- Longer DC string cables might need to opt for higher size of DC cable
- External DC switch box with SPD required to protect long DC strings
- Dedicated structures required for Inverter and AC combiner mounting at MV station
- Higher DC cable losses
- Many long DC string cables increase possibility of wiring mistakes

# 3

## DC System Design

This chapter on DC Systems Design contains the following information:

- String and Array Sizing Rules

## DC System Design

### DANGER

#### **ELECTRICAL SHOCK AND FIRE HAZARD**

Installation including wiring must be done by qualified personnel to ensure compliance with all applicable installation and electrical codes including relevant local, regional, and national regulations. Installation instructions are not covered in this Solution Guide but are included in the relevant product manuals for the Conext CL125 Inverter. Those instructions are provided for use by qualified installers only.

**Failure to follow these instructions will result in death or serious injury.**

Article 690 of NEC2017 and prior versions deals with installation and sizing guidelines for US and Canadian Electrical code CEC section C22.1 - Rule 64.

DC system design comprises of Module and Inverter technology assessment, string sizing, Arrangement and interconnection of strings, string cable sizing and length management, DC combiner box sizing if required, string / array cable sizing and routing up to the Inverter's terminal.

Out of the listed tasks, String sizing is the most important as many other decisions depend on it, such as the type and size of module mounting tables, interconnection arrangements, and cable routing.

## String and Array Sizing Rules

### To calculate the string size:

1. Gather the following technical information:
  - The following technical parameters from the PV modules:
    - Maximum open circuit voltage  $V_{oc}$
    - Maximum array short circuit current  $I_{sc}$
    - Maximum power point voltage  $V_{mpp}$  and current  $I_{mpp}$
    - Temperature coefficients for Power, Voltage, and Current
  - The following technical parameters from the Inverter:
    - Full power MPPT voltage range of CL125A (860V–1250V)
    - Operating voltage range (860V–1450V)
    - Maximum DC short circuit current (240A)
  - The following weather data:
    - Highest and lowest temperature at the location of installation
    - TMY or MET data set for location
2. Understand and ensure the rules of string sizing
  - Series-connected modules should not have open-circuit voltage higher than the Maximum  $V_{oc}$  limit of the inverter.

$$\text{Number of modules per string} \times V_{oc} \text{ (at } t_{\min}^{\circ}) < \text{inverter } V_{\max}$$

- Combined short circuit current of all parallel connected strings should not be higher than the Short Circuit current rating of the inverter (i.e., 240A). This should include any derating as required by local codes for defining the maximum  $I_{SC}$ .  
 $I_{sc \text{ strings}} < \text{inverter } I_{max}$
  - Series-connected modules should not have open circuit voltage lower than the lower limit of the MPPT voltage range of the Inverter (860V)  
 $\text{Number of modules per string} \times V_{mp} \text{ (at } t^{\circ}_{max}) < \text{inverter } V_{min}$
3. Calculate the Minimum Number of PV modules in Series
  4. Calculate the Maximum Number of PV modules in Series
  5. Calculate the total number of strings in Parallel

## Definitions

The following table defines the terms, symbols and acronyms used in calculations.

Term	Description
$N_{smin}$	Minimum number of PV Modules in series
$V_{min}$	Minimum string voltage for maximum power point tracking
$V_{max}$	Maximum string voltage for maximum power point tracking
$V_{maxr}$	Maximum module voltage at minimum operating cell temperature
$V_{oc}$	Open circuit voltage of the panels
$V_{minr}$	Minimum module voltage at maximum operating cell temperature
$\phi$	Coefficient of variation of voltage with temperature
$V_{mpp}$	Voltage at the point of maximum power
T	Temperature of the cell at STC
$T_c$	Temperature of the cell, ambient temperature
$T_{amb}$	Ambient temperature
$I_{inc}$	Incident radiation (maximum annual average)

Term	Description
NOCT	<p>Nominal operating cell temperature</p> <p>NOCT conditions define the irradiation conditions and temperature of the solar cell, widely used to characterize the cells, PV Modules, and solar PV inverters and defined as follows:</p> <p>Nominal Oper cell temp: 45±2 °C                      Irradiance: 800 W/m<sup>2</sup>                      Spectral distribution: Air Mass 1.5 G                      Cell temperature: 20°C                      Wind speed: 1 m/S</p>
I <sub>sc</sub>	Short circuit current of the module at STC
STC	<p>Standard Test Conditions for measurement</p> <p>STC conditions define the irradiation conditions and temperature of the solar cell, widely used to characterize the cells, PV Modules and solar generators and defines as follows:</p> <p>Irradiance: 1,000 W/m<sup>2</sup>                      Spectral distribution: Air Mass 1.5 G                      Cell temperature: 25° C</p>

### Use Case Example

PV Module: A typical 315 Wp Poly crystalline PV module parameters are considered

Inverter: Conext CL125A - 125kVA Inverter

Weather conditions: Maximum High Temperature is 36°C, Minimum Low Temperature is -25°C

	$\Delta V_{mpp}/T$ (φ)	V <sub>mpp</sub>	V <sub>mpp</sub> (70°C)	V <sub>oc</sub>
315Wp Poly crystalline, 6-inch PV module	-0.31% / °C	36.6	31.49	45.1

	V <sub>mpp</sub> Min (full power)	V <sub>oc</sub>	I <sub>sc</sub>
Conext CL125 Inverter	860V DC	1500V DC	240A DC

For a list of definitions, see “Definitions” on page 3–3.

## Minimum Number of PV Modules

CL125A has a start up voltage of 920 V and an operating MPPT window from 860V to 1250V. The minimum number of modules per PV string is important to ensure that 860V remains the output voltage and the Inverter gets early start up as much as possible.

For a list of definitions of terms used in the calculations, see “Definitions” on page 3–3.

At 36 °C ambient temperature, to determine the temperature of the cell in any situation, the following formula could be used.

$$T_c = T_{amb} + (I_{inc} (w/m^2) * (NOCT-20)/800)$$

$$T_c = 36^{\circ}\text{C} + ((1000) * (47 - 20) / 800) = 70^{\circ}\text{C}$$

To determine the temperature of the cell at STC, we use:

$$T = T_c - T_{stc}$$

$$T = 70^{\circ}\text{C} - 25^{\circ}\text{C} = 45^{\circ}\text{C}$$

To calculate the  $V_{mpp}$  of the module at the maximum temperature 70 °C, we use:

$$V_{mpp}(70^{\circ}\text{C}) = V_{mpp}(25^{\circ}\text{C}) - (T \times V_{mpp}(25^{\circ}\text{C}) \times \emptyset / 100)$$

$$V_{mpp}(70^{\circ}\text{C}) = 36.60\text{V} - (45 \times (36.60\text{V} \times 0.31\% / 100)) = 31.49\text{V} @ 70^{\circ}\text{C}$$

With this data we can calculate the minimum number of PV Modules to be connected in series to maintain full nameplate power

$$N_{s_{min}} = (V_{min} / V_{mpp}(70^{\circ}\text{C}))$$

$$N_{s_{min}} = (860 / 31.49) = 27.31$$

Rounding it up, **the answer is 28**. This is the minimum amount of PV Modules to be placed in series with each string to ensure the functioning of the inverter at 1000 W/m<sup>2</sup> and 36°C ambient temperature.

## Maximum Number of PV Modules

The maximum number of PV modules in a string for CL125A inverter is a ratio of highest system voltage (1500V) to the Maximum open circuit voltage at the lowest temperature.

For a list of definitions of terms used in the calculations, see “Definitions” on page 3–3.

At -25°C, to calculate the temperature needed for  $V_{oc}$ , we use:

$$T = T_{amb} - T_{stc}$$

$$T = -25^{\circ}\text{C} - 25^{\circ}\text{C} = -50^{\circ}\text{C}$$

To calculate the  $V_{oc}$  of the string at minimum temperature of -25°C

$$V_{oc}(-25^{\circ}\text{C}) = V_{oc}(25^{\circ}\text{C}) - (T \times V_{oc}(25^{\circ}\text{C}) \times \emptyset)$$

$$V_{oc}(-25^{\circ}\text{C}) = 45.1\text{V} - (-50 \times (45.10\text{V} \times 0.31\% / 100)) = 52.1\text{V} @ -25^{\circ}\text{C}$$

With this data we can calculate the maximum number of PV Modules to be connected in series to ensure the 1500V system sizing limit

$$N_{s \max} = (V_{\max} / V_{\max r})$$

$$N_{s \max} = (1500 / 52.1) = 28.79$$

Rounding it down, the answer will be **28**. This is the maximum amount of PV Modules to be placed in series with each string to ensure the functioning of the inverter at 1000 W/m<sup>2</sup> and -25°C ambient temperature.

**Calculating the Maximum the number of PV modules / string as per NEC**

NEC 690.7 provides the following table of voltage correction factors with respect to temperature to calculate the maximum open circuit voltage from PV module strings.

**Table 3-1** NEC 690.7 voltage correction factors

Lowest-Expected Ambient Temperature °C °F		Temperature Correction Factor
0 to 4	32 to 40	1.10
-1 to -5	23 to 31	1.12
-6 to -10	14 to 22	1.14
-11 to -15	5 to 13	1.16
-16 to -20	4 to -4	1.18
-21 to -25	-5 to -13	1.20
-26 to -30	-14 to -22	1.21
-31 to -35	-23 to -31	1.23
-36 to -40	-32 to -40	1.25

Table 3-1 indicates the temperature correction factors. Using this table, we determine the maximum PV source circuit voltage for N number of modules each rated V<sub>oc</sub> 45.1, at an ambient temperature of -25°C as follows:

$$PV \text{ Voc Table 690.7} = \text{Module Voc} \times \text{Table 690.7 Correction Factor} \times N \text{ (# Modules per Series String)}$$

$$1500V = 45.10 \text{ Voc} \times 1.2 \times N \text{ modules}$$

$$\text{Max.# of modules/string } N = 1500 / 54.12 = 27.71 \sim 28 \text{ Modules/String}$$

For a list of definitions of terms used in the calculations, see “Definitions” on page 3-3.



## Number of Strings in Parallel

The maximum number of strings installed in parallel connected to Conext CL125A inverters, will be calculated as follows:

$$\text{Number of Strings} = I_{sc} \text{ Inverter max} / (I_{sc})$$

$$\text{Max. \# of parallel strings} = 240A / 9.18A = 26.14 \text{ strings}$$

Rounding it down to **24 strings**

Since we have a physical connection limit of 12 (due to 12 DC string input in the DC combiner box), we will use all 12 inputs.

Table 3-2 shows an example of highest String sizing ratios with widely-used PV module ratings.

**Table 3-2** Example of highest string sizing ratios

PV Module type & rating	Poly Crystalline 315W	Mono Crystalline 265W
PV module series number	28	32
# of parallel strings	21	21
Total DC Power	185,220W	178,080W
Inverter rated power	125,000W	125,000W
DC/AC ratio	1.48	1.42

### Optimum DC-AC Ratio

DC Ratio is based on STC conditions, but does not consider the specific configuration of the project. The performance is a function of location and racking style. For example, a highly optimized system such as a 2-Axis tracker will have a much higher performance advantage compared to a 5-degree fix tilt. Likewise, a strong solar irradiance region will have a much higher energy potential than a weaker region. The amount of clipping losses will be based on the amount of relevant energy available vs. the inverter nameplate. As clipping exceeds 3%, there may be diminishing value to higher levels of DC Ratio.

Table 3-3 lists the suggested DC oversizing ranges for the Conext CL125 Inverter with various racking styles and locations.

**Table 3-3** Conext CL125 Inverter suggested DC oversizing range

Racking Style (location)	DC Oversizing Range
Steep Fix tilt (ground mount applications)	1.25 – 1.35
1-Axis Tracked (ground mount applications)	1.20 – 1.30
2-Axis Tracked (ground mount applications)	1.10 – 1.20

**Schneider Electric recommends a limit of 1.5 as a maximum. Higher DC/AC ratios will require review by a Schneider Electric applications engineer.**

1. The Conext CL125A has a single PV input with a direct connection from the Combiner Box. This Conext CL125A PV input can accept a cable size of maximum 200mm<sup>2</sup> (400kcmil).
2. The external DC Combiner can be designed with 30A fuses mounted on both polarities. While DC inputs are connected with Y connectors to combine two strings to each input, 15A in-line fuses should be considered (see *Figure 3-2*). Designers and Installers must consider this in the preliminary design.

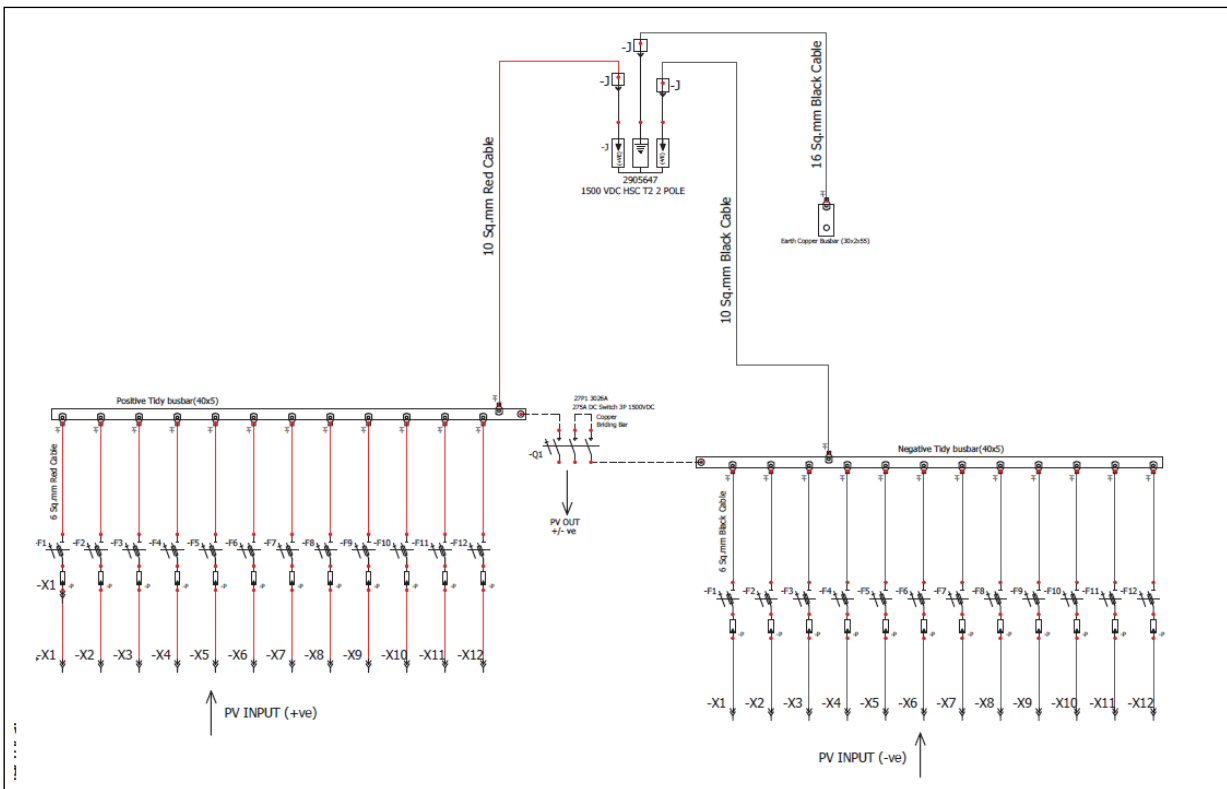

**Figure 3-1** Typical DC Combiner circuit diagram of CL Inverter

## NOTICE

### EQUIPMENT DAMAGE

Use only compatible Amphenol H4 mating connectors with the specified part numbers. Using mismatched connectors can cause corrosion and hotspots.

**Failure to follow these instruction can cause equipment damage.**

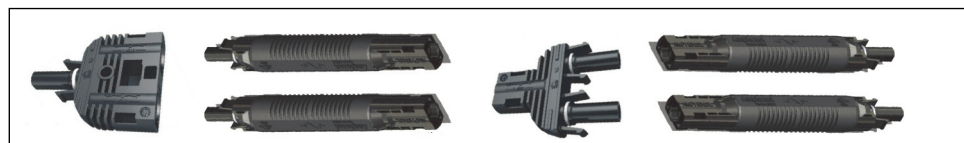

**Figure 3-2** Y-type connectors with in-line 15A fuse

**Recommended basic rules for string formation**

1. Select an EVEN number for modules in a string to have simpler string interconnectivity over mounting structures.
2. Try to maximize the modules per string within  $V_{oc}$  and  $V_{mpp}$  limits of the Inverter.
3. Formation of strings should be designed in a way that cable management at the back of modules could be followed as per electrical installation rules and with the shortest string cable length, as well as minimum bends.
4. Support the Connectors and avoid a sharp bend from the PV Module cable box.
5. If possible, keep the PV module strings connected and formed in horizontal lines to avoid shadow impact on all strings in each wing of racks or trackers.
6. Follow the instructions of the PV module manufacturer to select a Portrait or Landscape position of Modules.
7. Do not combine separate ratings of PV modules in one string.
8. The CL125A inverter is a transformer-less inverter, so it cannot be used with grounded arrays. This inverter is designed only for floating/ungrounded arrays. Before finalizing your PV system design, contact the PV module manufacturer.

**DC Cables**

Generally, in the US, the NEC code defines the use of USE-2 type single conductor PV wires for source circuit. AWG #12 and AWG # 8 are recommended sizes for CL125A. Installation should be in compliance with NEC 690.34 (D) & 690.8 (A)&(B).

In Canada, the CSA defines the use or RPVU-type wires with similar sizes.



# 4

## AC System Design

This chapter on AC Systems Design contains the following information:

- AC System Design
- AC Component Design

## AC System Design

### **DANGER**

#### **ELECTRICAL SHOCK AND FIRE HAZARD**

Installation, including wiring, must be performed by qualified personnel to ensure compliance with all applicable installation and electrical codes, including relevant local, regional, and national regulations. Installation instructions are not covered in this Solution Guide but are included in the relevant product manuals for the Conext CL125 Inverter. Those instructions are provided for use by qualified installers only.

**Failure to follow these instructions will result in death or serious injury.**

The AC system of a PV plant consists of an AC combiner box, AC recombiner box, AC Cables, LV-MV Transformer, MV switchgear at MV stations in the PV field, MV cable circuit and MV station at the Grid Box.

AC low voltage circuits with a high amount of power needs extreme care to achieve reliability, safety and the highest level of availability of the system. Selection of circuit breakers (MCB and MCCBs), Disconnect switches, Protection devices and Cables is the key to achieve all three objectives.

Safety and availability of energy are the designer's prime requirements.

Coordination of protection devices ensures these needs are met at optimized cost.

Implementation of these protection devices must allow for:

- the statutory aspects, particularly relating to safety of people
- technical and economic requirements

The chosen switchgear must:

- withstand and eliminate faults at optimized cost with respect to the necessary performance
- limit the effect of a fault to the smallest part possible of the installation to ensure continuity of supply

Achievement of these objectives requires coordination of protection device performance, necessary for:

- managing safety and increasing durability of the installation by limiting stresses
- managing availability by eliminating the fault by means of the circuit breaker immediately upstream.

## AC Component Design

### AC Conductor sizing

The AC Cable sizing calculation consists of ampacity, voltage drop, short circuit calculation and thermal de-rating of AC cables.

To limit the power loss up to acceptable limits, after selecting a suitable size of cable with proper ampacity, short circuit rating and voltage grade, the most important part is to calculate voltage drop. We advise keeping the AC cable overall power losses in the range of <1%. This would ensure smooth operation of multiple units in parallel at one transformer LV winding.

Formulae commonly used to calculate voltage drop in a given circuit per kilometer of length.

$$\Delta U = \sqrt{3} I_s (R \cos \phi + X \sin \phi) L$$

$$\%V_d = \frac{100 \Delta U}{U_n}$$

Where:

- X – inductive reactance of a conductor in  $\Omega/\text{km}$
- $\phi$  – phase angle between voltage and current in the circuit considered
- $I_s$  – the full load current in amps
- L – length of cable (km)
- R – resistance of the cable conductor in  $\Omega/\text{km}$
- $v_d$  – voltage drop
- $U_n$  – phase to phase voltage

AC cable sizes between Conext CL125 Inverters and AC combiner boxes will be governed by Inverter maximum output current (120A) as per NEC 690.8 (A)(3). A higher size could be selected depending on the distance between the inverter and the AC combiner. The output current of the Conext CL125 Inverter is 120A. Considering the de-rating factors due to cable laying methodology and thermal de-rating due to conduits, mostly #350 kcmil AL or 3/0 Cu conductors fit in to the most instances.

Table 4-1 provides the recommended maximum Cu cable lengths for AWG #3/0, 4/0 and 250 kcmil conductor size from inverter to AC Combiner box. It indicates tentative figures for power loss with respect to length and size. We advise the installer to carry out a detailed cable-sizing calculation specifically for each inverter and location.

It is essential to calculate and consider the correct fault level on each combiner bus level to select the right size of cable, MCB, MCCB and RCD, Surge protection and Disconnect devices.

The following methodology can help to understand this calculation.

If the AC cable length exceeds 10 m (32.8ft), the use of an AC switch box closer to the inverter is recommended. This switchbox can be used to connect a higher size of cable, if required to avoid voltage drop.

**Table 4-1** Percentage losses for Cu cable w.r.t maximum AC cable length

AC Cable length	#3/0 AWG	4/0 AWG	250 kcmil
<b>125 kVA - % losses for copper cable</b>			
25m	0.19%	0.15%	0.13%
50m	0.38%	0.3%	0.26%
75m	0.57%	0.45%	0.39%
100m	1.14%	0.9%	0.52%

Aluminum cables can be used to connect Conext CL Inverter output to the AC combiner box. The designer/installer must be careful about calculating the cable voltage drop and power loss while designing the system especially when using Aluminum cables.

It is very important to consider both resistive and reactive components of voltage drop when calculating cable sizing. The Reactive component of cable Impedance plays an essential role in parallel operation of Inverters. The target should be to reduce the reactive impedance as much as possible to increase the number of parallel connected inverters at LV winding of the Transformer (considering intermediate AC distribution boxes).

## AC Combiner Box

AC combiner box is first level combiners, mostly located in the PV field in large utility scale projects. AC combiner box houses the first level protection for Inverters on the AC side (if not applied in the AC box). The outgoing line from the AC combiner to the LV/MV station holds disconnects or, if required, it should be protected with circuit breakers.



**Figure 4-1** Type 3R AC combiner box enclosure



## Function

1. Combines AC currents coming from several inverters.
2. Isolates the combiner box from the AC line.
3. Output - Main Lugs only or Circuit Breaker.
4. Circuit breaker (according to prospective current).
5. Protects inverters against voltage surges from the AC line.
6. Surge Logic IMA device for surge protection.

## Typical use

1. AC combiner box is located near the inverters.
2. Long distance between the AC combiner box and the AC distribution box.
3. Requires high cross-section terminals for output cabling.

Depending on the number of inverters being combined at the AC combiner's bus-bar, the incoming lines can be protected using MCBs or MCCBs. The selection of this component depends on rated circuit current, expected fault current, fault clearing time and remote operation requirements. The length of the cable connected between AC combiner output and AC recombiner input plays an important role as a longer length reduces the fault current to break.

The maximum fault contribution is based on the MV transformer fault current, which is a function of the power rating and the primary to secondary impedance. The Resulting Fault level at the AC combiner bus bar will vary and the choice of 125A MCCB should consider the application.

### Methodology to calculate the fault level at AC combiner bus-bar

For a combiner box connected to a re-combiner box with 400mm<sup>2</sup> size AL cable of 100m length and the re-combiner box connected to a 2500kVA 20kV/600V, 6% transformer.

Calculating short circuit current on AC combiner bus-bar:

$$I_{CC} = \frac{V_0}{\sqrt{3} \times \sqrt{(R_{LV-GRID} + R_{TR-LV} + R_{CABLE})^2 + (X_{LV-GRID} + X_{TR-LV} + X_{CABLE})^2}}$$

Where:

- $R_{CABLE}$  – AC cable resistance
- $X_{CABLE}$  – AC cable reactance
- $I_{CC}$  – Short circuit fault current
- $V_0$  – Grid voltage
- $R_{LV-GRID}$  – LV grid resistance
- $R_{TR-LV}$  – Transformer resistance on LV side
- $X_{LV-GRID}$  – LV grid reactance
- $X_{TR-LV}$  – LV winding Reactance of the transformer

Where cable values are calculated as:

$$R_{\text{CABLE}} = 0.09909 \frac{\Omega}{\text{KM}} \times (0.01) = 9.909 \times 10^{-3} \Omega$$

$$X_{\text{CABLE}} = 0.08 \frac{\Omega}{\text{KM}} \times (0.05) = 0.004 \Omega$$

#### Grid LV Impedance:

Considering the MV connection at 20kV and Grid short circuit power of 500MVA, we will use following values to calculate Grid impedance at the LV side of the transformer.

MV voltage: 20kV

Short circuit power from grid: 500MVA

Transformer LV voltage: 600V

Size of transformer: 2500KVA

#### First, calculate MV impedance:

$$Z_{\text{MV-GRID}} = \frac{V^2}{S_{\text{cc}}} = \frac{20000^2}{500 \times 10^6} = 0.8 \Omega$$

Then, for 20kV grid,

$$\frac{R_{\text{MV-GRID}}}{Z_{\text{MV-GRID}}} \approx 0.2$$

$$X_{\text{MV-GRID}} = 0.980 Z_{\text{MV-GRID}} = 0.784 \Omega$$

$$R_{\text{MV-GRID}} = 0.16 \Omega$$

Then, calculate Grid LV impedance from Grid MV values:

$$X_{\text{LV-GRID}} = X_{\text{MV-GRID}} \left( \frac{V_{\text{LV}}}{V_{\text{MV}}} \right)^2 = 7.05 \times 10^{-4} \Omega$$

$$R_{\text{LV-GRID}} = R_{\text{MV-GRID}} \left( \frac{V_{\text{LV}}}{V_{\text{MV}}} \right)^2 = 1.44 \times 10^{-4} \Omega$$

Then, calculate Transformer impedance values and Transformer LV impedance:

$$Z_{\text{TR-LV}} = U_{\text{cc}} \frac{V^2}{S_{\text{N}}} = 0.06 \frac{600^2}{2500 \times 10^3} = 8.64 \times 10^{-3} \Omega$$

$$R_{\text{TR-LV}} = \frac{\text{Losses}}{3 I_{\text{N}}^2} = 1.458 \times 10^{-3} \Omega$$

$$X_{\text{TR-LV}} = \sqrt{(Z_{\text{TR-LV}})^2 - (R_{\text{TR-LV}})^2} = 8.517 \times 10^{-3} \Omega$$

Using the above four values in the formulae for the Bus-bar fault level calculation,

$$I_{cc} = 16.7\text{kA}$$

So for this scenario, a >25KA will be the choice of circuit breakers with the calculated fault current.

The selection of Switch-disconnect for the AC combiner box also depends on this fault current and the nominal continuous current that the AC combiner box is going to handle.

## NOTICE

### EQUIPMENT DAMAGE

Carefully consider the length, as well as the cable, to select the most economical yet effective and safe circuit breaker solution. The size and type of cable selected affects the fault level on the AC combiner box bus-bar.

**Failure to follow these instructions can cause equipment damage.**

### Selection Recommendations for AC Combiner Box

Square D®-brand I-Line® circuit breaker power distribution panelboards are for use on AC or DC systems. The panels, labeled  $cUL_{US}$  (compliance to UL and CSA standards certified by UL) are also Underwriters Laboratories® (UL®) Listed under File E33139. The following are suitable for use as service entrance equipment:

- All main circuit breaker panelboards.
- All main lugs panelboards with branch-mounted, back-fed main circuit breaker. (For Canadian MLO service entrance, use HCP-SU and HCR-U only).
- All main lugs panelboards with six disconnects or less.
- A solid neutral that is insulated, but may be bonded to the box with a grounding strap.
- Service entrance panelboards meeting the requirements of CSA are available in Canada factory-assembled only. I-Line circuit breaker panelboards are available as 225–1200 A main lugs only and 100–1200 A main circuit breakers.
- I-Line panelboards are designed to accept the following circuit breakers: FY, FA, FH, FC, FJ, FK, FI, HD, HG, HJ, HL, QB, QD, QG, QJ, QO, KA, KH, KC, KI, JD, JG, JJ, JL, LA, LH, LC, LI, LE, LX, LXI, MA, MH, MG, MJ, PG, PJ, PK\*, PL, RG, RJ, RK\*, and RL.\* Canada only.

Panelboard Types						
Panelboard Type	Maximum Mains Ampacity		Maximum Branch Circuit Breaker Frame Size ♦		Enclosure Dimensions ■	
	Main Lugs	Main Circuit Breakers	Left	Right	Width IN (mm)	Depth IN (mm)
HCN	600 A	400 A	FA, QB, HD	FA, QB, HD	26 (660)	6.50 (165)
HCM	800 A	800 A	JD	JD	32 (813)	8.25 (210)/ 9.50 (241)
HCP-SU	800 A	800 A ♦	MG, PG	None	26 (600)	9.50 (241)
HCP	1200 A	800 A ♦	MG, PG	JD	42 (1067)	9.50 (241)
HCR-U	1200 A	1200 A ♦	RG	JD	44 (1118)	9.50 (241)

♦ For a complete listing of applicable circuit breaker types, refer to the dimensions section.  
 ■ Refer to the Dimensions section for standard panelboard heights.  
 ♦ Available as a main circuit breaker panelboard when provided with a branch mounted back-fed main circuit breaker.

Figure 4-2 AC combiner panelboard options

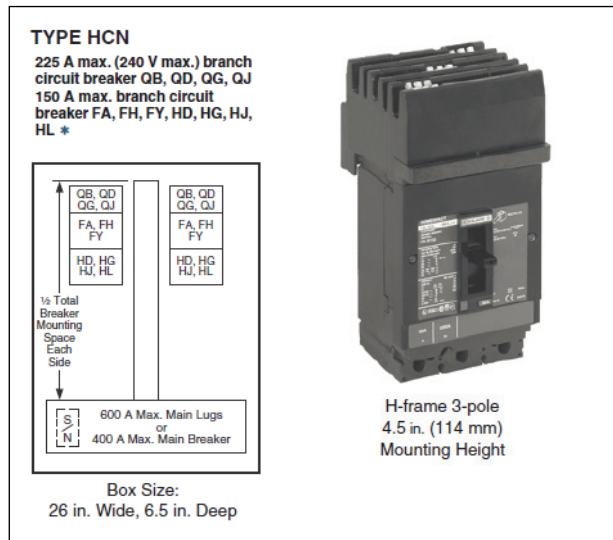

Figure 4-3 Recommended type of HCN for AC combiner panel

I-Line <sup>®</sup> Merchandised Panelboards										600 Vac, 250 Vdc				
										Class 2110 / Refer to Catalog 2110CT9701				
Table 9.96: Interiors, Boxes and Fronts (100 A and 225 A Interiors include solid neutral, all others without solid neutral. Order solid neutral from 9-23)														
Total Circuit Breaker Mounting Space (in.)	Mains Amperes Rating	Complete Surface \$ Price (4 Piece Trim) (Less Branch Circuit Breakers)		Interior Assembly (Less Branch Circuit Breakers)		Front ▲				Box ◆				
		Type 1 \$ Price	Type 3R/5/12 \$ Price	Catalog Number	\$ Price	4 Piece Trim Without Door ■		Trim With Door		Type 1		NEMA 3R/5/12* (Includes Front)		
		Catalog Number	\$ Price	Catalog Number	\$ Price	Catalog Number	\$ Price	Catalog Number	\$ Price	Catalog Number	\$ Price	Catalog Number	\$ Price	
<b>HCN Main Lugs Only</b>														
<b>3-pole—Suitable for use as service equipment when provided with a main circuit breaker. ☆</b>														
27	225	2171.	4004.	HCN14522N	1593.	HCN52T( )	335.	HCN52T( )D	411.	HC2652B	243.	HC2652WP	2411.	52
	400	2195.	4028.	HCN14524	1617.									
	600	2392.	4225.	HCN14526	1814.									
45	225	2674.	4402.	HCN23652N	1991.	HCN65T( )	440.	HCN65T( )D	530.	HC2665B	243.	HC2665WP	2411.	65
	400	2702.	4430.	HCN23654	2019.									
	600	2960.	4668.	HCN23656	2277.									
63	225	3135.	4709.	HCN32742N	2298.	HCN74T( )	594.	HCN74T( )D	717.	HC2674B	243.	HC2674WP	2411.	74
	400	3156.	4730.	HCN32744	2319.									
	600	3396.	4970.	HCN32746	2559.									
81	225	3548.	6233.	HCN41832N	2552.	HCN83T( )	753.	HCN83T( )D	890.	HC2683B	243.	HC2683WP	3681.	83
	400	3564.	6249.	HCN41834	2568.									
	600	3824.	6509.	HCN41836	2828.									
99	225	4175.	6767.	HCN50922N	3086.	HCN92T( )	846.	HCN92T( )D	1001.	HC2692B	243.	HC2692WP	3681.	92
	400	4341.	6933.	HCN50924	3252.									
	600	4434.	7026.	HCN50926	3345.									
<b>HCN Main Circuit Breaker ▼ ◆</b>														
<b>Includes 3-pole, vertically mounted main circuit breaker—Suitable for use as service equipment</b>														
18	100	3371.	5204.	HCN09521MN	2793.	HCN52T( )	335.	HCN52T( )D	411.	HC2652B	243.	HC2652WP	2411.	52
	225	4892.	6725.	HCN09522MN	4314.									
27	400	6649.	8377.	HCN14654M	5966.	HCN65T( )	440.	HCN65T( )D	530.	HC2665B	243.	HC2665WP	2411.	65
	100	3860.	5588.	HCN18651MN	3177.									
	36	225	5303.	7031.	HCN18652MN	4620.								
45	400	7287.	8861.	HCN23744M	6450.	HCN74T( )	594.	HCN74T( )D	717.	HC2674B	243.	HC2674WP	2411.	74
	100	4323.	5897.	HCN27741MN	3486.									
	225	5759.	7333.	HCN27742MN	4922.									
63	225	6068.	8753.	HCN32832MN	5072.	HCN83T( )	753.	HCN83T( )D	890.	HC2683B	243.	HC2683WP	3681.	83
	400	7836.	10521.	HCN32834M	6840.									
81	400	8154.	10746.	HCN41924M	7065.	HCN92T( )	846.	HCN92T( )D	1001.	HC2692B	243.	HC2692WP	3681.	92
	225	6590.	9182.	HCN45922M	5501.									

Figure 4-4 AC combiner - HCN panelboard trims and options (with main CB or MLO)

H- and J-frame											
Table 9.116: H-frame 150 A Standard Rated Thermal Magnetic (600 Vac) with Factory Sealed Trip Units											
Ampere Rating	AC Magnetic Trip Setting		D Interrupting		G Interrupting		J Interrupting ▲		L Interrupting ▲		Terminal Wire Range
	Hold	Trip	Catalog No.	\$ Price	Catalog No.	\$ Price	Catalog No.	\$ Price	Catalog No.	\$ Price	
<b>2-pole, 600 Vac 50/60 Hz</b>											
15	350	750	HDA26015( )	899.	HGA26015( )	1338.	HJA26015( )	1589.	HLA26015( )	2483.	AL150HD #14-#3/0 AWG Al or Cu
20			HDA26020( )		HGA26020( )		HJA26020( )		HLA26020( )		
25			HDA26025( )		HGA26025( )		HJA26025( )		HLA26025( )		
30	HDA26030( )	HGA26030( )	HJA26030( )	HLA26030( )							
35	HDA26035( )	HGA26035( )	HJA26035( )	HLA26035( )							
40	HDA26040( )	HGA26040( )	HJA26040( )	HLA26040( )							
45	HDA26045( )	HGA26045( )	HJA26045( )	HLA26045( )							
50	HDA26050( )	HGA26050( )	HJA26050( )	HLA26050( )							
60	HDA26060( )	HGA26060( )	HJA26060( )	HLA26060( )							
70	HDA26070( )	HGA26070( )	HJA26070( )	HLA26070( )							
80	HDA26080( )	HGA26080( )	HJA26080( )	HLA26080( )							
90	HDA26090( )	HGA26090( )	HJA26090( )	HLA26090( )							
100	HDA26100( )	HGA26100( )	HJA26100( )	HLA26100( )							
110	HDA26110( )	HGA26110( )	HJA26110( )	HLA26110( )							
125	HDA26125( )	HGA26125( )	HJA26125( )	HLA26125( )							
150	HDA26150( )	HGA26150( )	HJA26150( )	HLA26150( )							
<b>3-pole, 600 Vac 50/60 Hz</b>											
15	350	750	HDA36015	1124.	HGA36015	1575.	HJA36015	1988.	HLA36015	2993.	AL150HD #14-#3/0 AWG Al or Cu
20			HDA36020		HGA36020		HJA36020		HLA36020		
25			HDA36025		HGA36025		HJA36025		HLA36025		
30	HDA36030	HGA36030	HJA36030	HLA36030							
35	HDA36035	HGA36035	HJA36035	HLA36035							
40	HDA36040	HGA36040	HJA36040	HLA36040							
45	HDA36045	HGA36045	HJA36045	HLA36045							
50	HDA36050	HGA36050	HJA36050	HLA36050							
60	HDA36060	HGA36060	HJA36060	HLA36060							
70	HDA36070	HGA36070	HJA36070	HLA36070							
80	HDA36080	HGA36080	HJA36080	HLA36080							
90	HDA36090	HGA36090	HJA36090	HLA36090							
100	HDA36100	HGA36100	HJA36100	HLA36100							
110	HDA36110	HGA36110	HJA36110	HLA36110							
125	HDA36125	HGA36125	HJA36125	HLA36125							
150	HDA36150	HGA36150	HJA36150	HLA36150							

Figure 4-5 H frame circuit breaker (125-150A) for AC combiner panel

#### Short Circuit Current Rating (SCCR)

- SCCR is equal to the lowest interrupting capacity of a branch or main circuit breaker installed in the panelboard.
- I-Line panelboards, with branch circuit breakers installed, are short-circuit tested as complete units.
- All tests are conducted in accordance with UL 67 and CSA C22.2 (Standards for Panelboards). With I-Limiter main circuit breaker, I-Line main circuit breaker panelboards are UL/CSA Listed for use on systems with up to a 200,000 maximum RMS symmetrical amperes available fault current (100 kA @ 600 VAC).

#### Surge Protection for AC Combiners

##### I-Line Plug-on Unit with Surgelagic® TVSS

- Plug-on design requires less cable and conduit than end gutter-mounted TVSS unit, saving labor time and material costs.
- Bus-connected design enhances performance.
- Meets the requirements of UL and CSA for retrofit applications in existing I-Line panelboards and switchboards.
- Integrated TVSS and circuit breaker disconnects feature compact design, requiring only 13.50 inches (343 mm) of branch mounting space.
- SCCR up to 240 kA rating (100 kA @ 600 VAC) meets a wide variety of customer applications



**Figure 4-6** I-Line Surgelagic TVSS Ubl

##### Branch Mounted TVSS for I-LINE®, QMB and QMQB Distribution Sections

- Suitable for use in service entrance locations.
- Meets requirements of ANSI/IEEE C62.41 and C62.45, UL 1283 and UL 1449 Second Edition.
- Standard product protection modes L-N, L-G, L-L and N-G
- Audible alarm with enable/disable switch and dry contact standard
- Standard internal 200 kAIR (interrupting rating) surge rated fusing
- Short circuit current rating 200 kA
- EMI/RFI filtering



**Figure 4-7** I-Line plug-on unit with SurgeLogic TVSS

**Table 4-2** SurgeLogic TVSS branch unit options

Voltage	Surge Current Rating	I-LINE Branch Units
		Catalog No.
600V, 3-phase, 3-wire + ground	120 kA	HR9IMA12C
	160 kA	HR9IMA16C
	240 kA	HR9IMA18C

## AC Re-combiner Box

The AC re-combiner box is adapted according to the type of grid box and the requirements of the utility.



**Figure 4-8** AC re-combiner box

The AC re-combiner box is divided into two parts:

- LV AC re-combiner connects to all AC combiner boxes while protecting the cabling and possibly measuring currents
- LV connection connects to the grid box while ensuring compatibility with the grid box and utility requirements

The AC re-combiner box re-combines all AC combiner boxes at one bus-bar and accumulated power flows to the transformer LV winding to get transferred to MV network.

AC re-combiner box is usually located at an LV-MV station inside the kiosk or outside on a concrete pad. All incomers from AC combiners in the PV field are connected to the molded case type circuit breakers. The Outgoing to the LV transformer winding from the AC re-combiner box can be connected to either an MCCB or an Air circuit breaker depending on the space requirements.

It is worth noting that discrimination and cascading of circuit breakers helps to design a more accurate protection philosophy, as well as save on capital costs due to the reduced fault level capacity of components.

The fault level at the transformer's LV terminal will be mostly the same as the fault level on the AC re-combiner's bus-bar due to the very short distance between the Transformer and the re-combiner panel.



### Methodology to calculate Fault level on AC re-combiner's bus bar

The following variables are used in the calculations:

Variable	Definition
$I_{CC}$	Short circuit fault current
$S_{CC}$	Short circuit power from grid
$S_n$	Transformer kVA
$V_o$	Grid voltage
$R_{LV-GRID}$	LV grid resistance
$R_{MV-GRID}$	MV grid resistance
$R_{TR-LV}$	Transformer resistance on LV side
$X_{LV-GRID}$	LV grid reactance
$X_{MV-GRID}$	MV grid resistance
$X_{TR-LV}$	LV winding Reactance of the transformer
$Z_{MV-GRID}$	MV grid impedance

Fault level at AC re-combiner bus bar:

$$I_{CC} = \frac{V_o}{\sqrt{3} \times \sqrt{(R_{LV-GRID} + R_{TR-LV})^2 + (X_{LV-GRID} + X_{TR-LV})^2}}$$

Considering the MV connection at 20kV and Grid short circuit power of 500MVA, we will use following values to calculate Grid impedance at the LV side of the transformer.

MV voltage: 20kV

Short circuit power from grid: 500MVA

Transformer LV voltage: 600V

Voltage factor c for MV grid: 1.1

Size of transformer: 2500kVA

**First, calculate MV impedance:**

$$Z_{MV-GRID} = \frac{V^2}{S_{CC}} = \frac{20000^2}{500 \times 10^6} = 0.8 \Omega$$

**Then, for 20kV grid,**

$$\frac{R_{MV-GRID}}{Z_{MV-GRID}} \approx 0.2$$

$$X_{MV-GRID} = 0.980 Z_{MV-GRID} = 0.784 \Omega$$

$$R_{MV-GRID} = 0.16\Omega$$

Then, calculate Grid LV impedance from Grid MV values:

$$X_{LV-GRID} = X_{MV-GRID} \left( \frac{V_{LV}}{V_{MV}} \right)^2 = 7.05 \times 10^{-4} \Omega$$

$$R_{LV-GRID} = R_{MV-GRID} \left( \frac{V_{LV}}{V_{MV}} \right)^2 = 1.44 \times 10^{-4} \Omega$$

Then, calculate Transformer impedance values and Transformer LV impedance:

$$Z_{TR-LV} = U_{CC} \frac{V^2}{S_N} = 0.06 \frac{600^2}{2500 \times 10^3} = 8.64 \times 10^{-3} \Omega$$

$$R_{TR-LV} = \frac{\text{Losses}}{3I_N^2} = 1.458 \times 10^{-3} \Omega$$

where Losses is full load = 23000W, no load = 2200W, and Total = 25200W.

$$X_{TR-LV} = \sqrt{(Z_{TR-LV})^2 - (R_{TR-LV})^2} = 3.37 \times 10^{-3} \Omega$$

Using the above four values in the formulae for the Bus-bar fault level calculation,

$$I = 38.5 \text{ kA}$$

The selection of incoming circuit breaker, bus-bar and outgoing circuit breaker shall be based on this fault-level calculation and nominal-rated current.

For a 2500 kVA standard block, with 20 Conext CL125 Inverters, 5 AC combiner boxes combining 4 inverters each, the AC re-combiner box will have 5 incomers, each with 480A nominal current and respective fault level. The length of cables between the AC re-combiner and the transformer (being very short) doesn't make much difference to the selection of the circuit breaker's fault level. Transformer impedance and grid short-circuit fault level makes a small difference but is not significant. The major difference comes from the size of the transformer and LV voltage level. The designer should consider this when designing the system.

#### Selection Recommendations for AC Re-combiner Box

QED-2 with group mounted I-LINE circuit breakers offer additional branch mounting flexibility because breakers with different frame sizes and number of poles can mount anywhere on the bus stack.

QED-2 distribution sections include I-Line® circuit breakers. With I-Line plug-on circuit breaker construction, the line end of the circuit breaker plugs directly onto the I-Line panel bus assembly. This design allows you to quickly install and wire circuit breakers from the front of the switchboard. In addition, I-Line circuit breakers are keyed to mounting slots in the support pan for automatic alignment and faster installation.

I-Line switchboard sections are available in single- or double-row construction. If you require higher feeder ampacities, QED-2 switchboards are available with individually mounted branch devices up to 4,000A. They include both thermal-magnetic and electronic trip molded case circuit breakers. For equipment ground-fault protection you can use electronic trip. With QED-2 switchboards, you can also specify options such as automatic throw-over systems.

**Features**

- 6000A maximum bus design.
- Copper bus silver plated (immersion).
- Aluminum bus tin plated up to 2000A.
- Main devices include Masterpact NW, MCCB's or Bolt-Loc switches.
- Free standing, cable-fed distribution-only section available.
- Bottom entry main section available without wireway.
- Available bus duct entry.
- Painted steel construction. All covers painted ASA49 gray.
- CSA general purpose (type 1) enclosure standard.
- Floor mounted, free standing.
- Channel base supplied as standard.
- CSA C22.2, No. 31 approved.

**Main device ratings for AC re-combiner**

Main Devices (MCCB)			Main Devices (Masterpact NW - Micrologic Trip, 100% Rated)	
Ampere Rating	Trip Unit	Catalogue Number	Ampere Rating	Catalogue Number
800	Thermal-Magnetic	Powerpact M (MG,MJ)	1600	NW16
		Powerpact P (PG,PJ,PK,PL)	2000	NW20
	Electronic Trip	Powerpact P (PG,PJ,PK,PL)	3000	NW30
		Powerpact R (RG,RJ,RK,RL)	4000	NW40
1000	Thermal-Magnetic	Powerpact P (PG,PJ,PK,PL)	5000	NW50
		Powerpact P (PG,PJ,PK,PL)	6000	NW60
	Electronic Trip	Powerpact P (PG,PJ,PK,PL)		
		Powerpact R (RG,RJ,RK,RL)		
1200	Thermal-Magnetic	Powerpact P (PG,PJ,PK,PL)		
		Powerpact R (RG,RJ,RK,RL)		
	Electronic Trip	Powerpact P (PG,PJ,PK,PL)		
		Powerpact R (RG,RJ,RK,RL)		
1600	Thermal-Magnetic	Powerpact R (RG,RJ,RK,RL)		
		Powerpact R (RG,RJ,RK,RL)		
	Electronic Trip	Powerpact R (RG,RJ,RK,RL)		
		Powerpact R (RG,RJ,RK,RL)		
2000	Thermal-Magnetic	Powerpact R (RG,RJ,RK,RL)		
		Powerpact R (RG,RJ,RK,RL)		
	Electronic Trip	Powerpact R (RG,RJ,RK,RL)		
		Powerpact R (RG,RJ,RK,RL)		
2500	Thermal-Magnetic	Powerpact R (RG,RJ,RK,RL)		
		Powerpact R (RG,RJ,RK,RL)		
	Electronic Trip	Powerpact R (RG,RJ,RK,RL)		
		Powerpact R (RG,RJ,RK,RL)		

Main Devices (Fusible)	
Ampere Rating	Device Type
1600	Bolt-Loc
	Bolt-Loc With Ground Fault
2000	Bolt-Loc
	Bolt-Loc With Ground Fault
2500	Bolt-Loc
	Bolt-Loc With Ground Fault
3000	Bolt-Loc
	Bolt-Loc With Ground Fault

**Figure 4-9** Main device (MCCB/Masterpact NW / Fuse) rating table for AC re-combiner

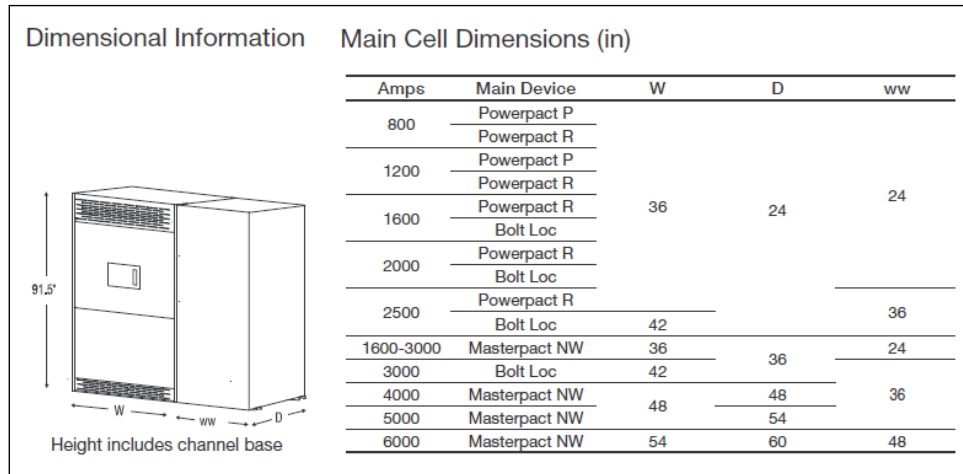

Figure 4-10 AC re-combiner size details (option specific)

Distribution Sections			
Distribution Type	Allowable Branch Device Frame	Distribution Type	Allowable Branch Device Frame
QMB/QMJ mounting, Single Row 72" Mounting Height 2000A Max.	QMB/QMJ Fusible Switch 36" Wide (400A Max) 42" Wide (800A Max) 48" Wide (1200A Max)	QMQB mounting, Single Row 106X Mounting Height 2400A Max.	QMQB Fusible Switch 42" Wide (1200A Max)
MQS mounting, Single Row 98X <sup>2</sup> Mounting Height 2400A Max.	MQS Fusible Switch with Sub-Meter 48" Wide (30-200A Max)		

\* Maximum 600A feeder due to bending space restrictions.

Notes:

- Using a 1200A QMQB in the distribution section takes up additional X space. If top exit, remaining space is 44X. If bottom exit, remaining space is 26X. Only one 1200A QMQB per distribution section. 1200A QMQB space eliminates extra bus (no additional feeders).
- Some utilities may limit available MQS height to 70X.
- The distribution section depth will match the main section unless otherwise noted.

Figure 4-11 Distribution section options for QED-2 type AC re-combiner

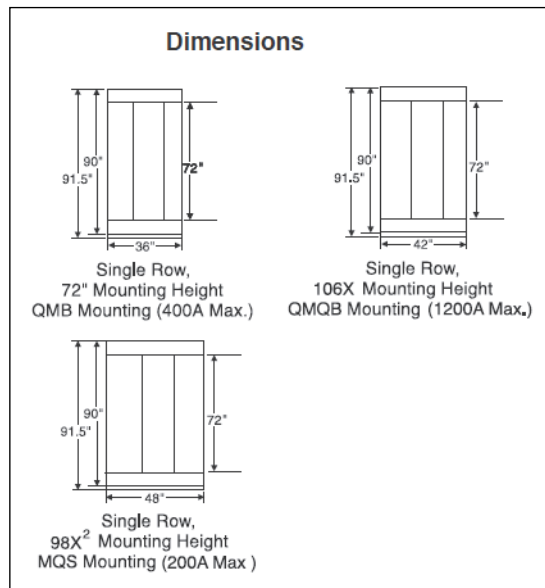

**Figure 4-12** QED-2 type AC re-combiner distribution section sizes (type specific)

Recommended section size - Option: 36" wide Single row I-Line

CB Frame	CB Mounting Height inches (mm) (ii)	Single Row I-Line Distribution Sections		
		36" Wide (3000A Max.)	42" Wide (3000A Max.)	48" Wide (3000A Max.)
QO (i)	N/A	30A	30A	30A
QO-VH (i)	N/A	30A	30A	30A
QH (i)	N/A	30A	30A	30A
F	4.5" (114)	100A	100A	100A
H	4.5" (114)	150A	150A	150A
Q	4.5" (114)	225A	225A	225A
J	4.5" (114)	250A	250A	250A
L	6" (152)	600A	600A	600A
M	9" (229)	800A	800A	800A
P	9" (229)	1200A	1200A	1200A
R	15" (381)	1200A (max)	1200A (max)	1200A (max)

**Notes:**  
 (i) Must be used with QO I-Line adapter  
 (ii) Mounting height based on a 3-pole breaker

**Figure 4-13** Width options for distribution sections of QED-2 AC re-combiner

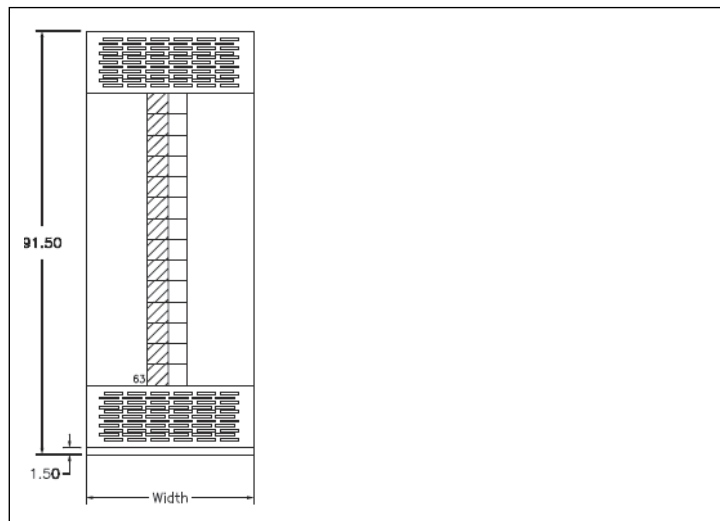

**Figure 4-14** Expected size for single row distribution section

## Function

1. Combines AC currents coming from the AC combiner boxes.
2. Connects to the grid box while ensuring compatibility with the grid box and compliance with grid connection requirements.
3. Protects the AC lines connected to the AC combiner boxes
  - using rated current and Fault level at the bus-bar
4. Protects against voltage surges coming from AC lines
  - using type 1 or type 2 SPD, protected by circuit breaker.
5. Isolates the AC re-combiner box (and the whole PV installation) from the AC line.
6. Optionally, monitors currents and energies at each input.
7. When a remote emergency shutdown is required, an optional release MN or MX is used at the LV connection stage.

## Typical use

1. Different types of AC re-combiner box are required according to the type of grid box and to the need for an external protective relay.
2. In the case of connecting only one AC combiner box, only the LV connection stage of the AC re-combiner box is required.
3. The AC re-combiner box can be located indoors or outdoors, normally close to the grid box.
4. Buildings protected with lightning rods require the use of type 1 SPDs at AC re-combiner box level.

## Recommended System Design

We recommend the following configuration for reliability and higher system availability.

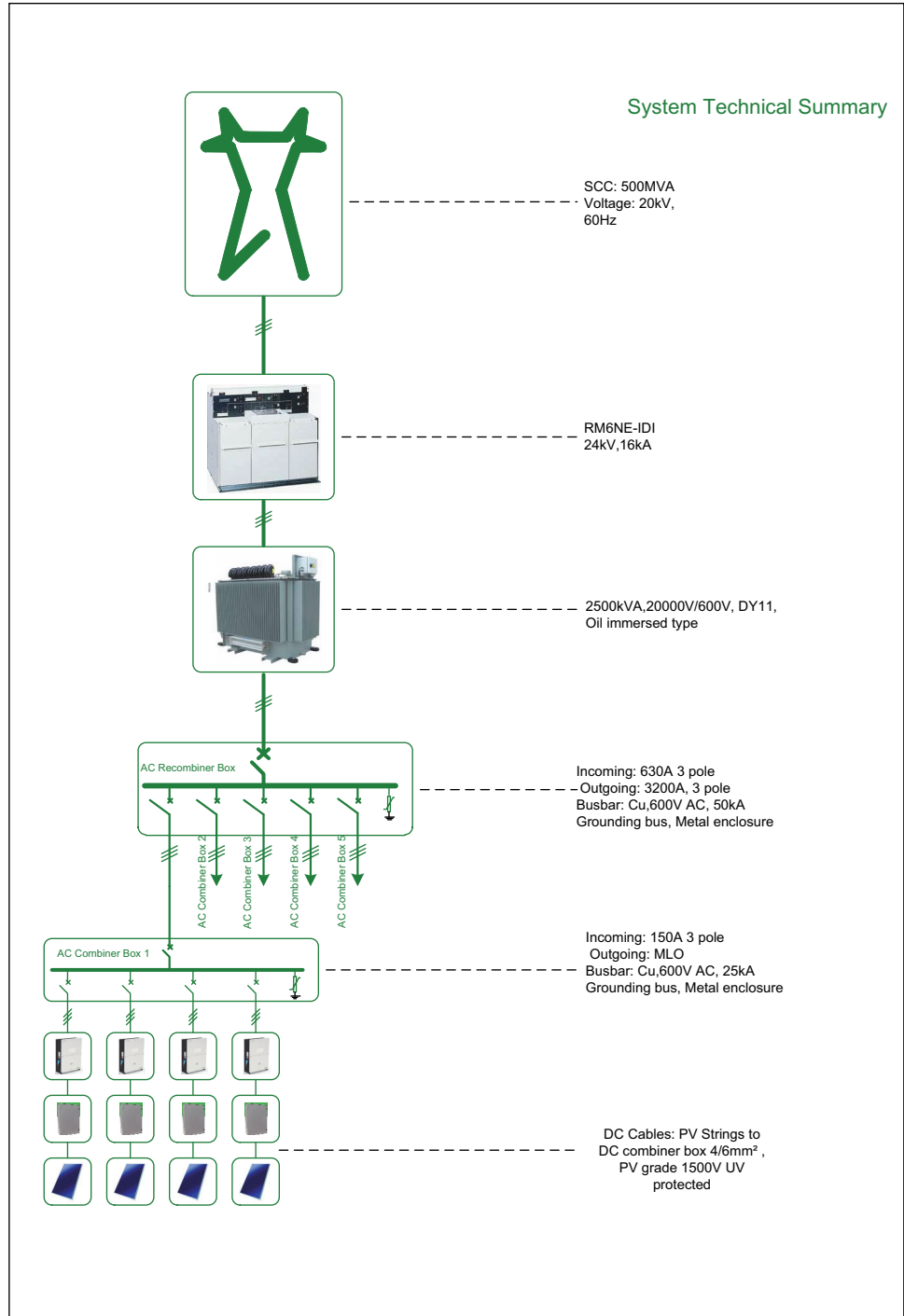





# 5

## Important Aspects of a Decentralized System Design

This chapter on the aspects of a decentralized system design contains the following information:

- Grounding System Design for Decentralized PV systems
- Grid Connection
- Role of Circuit Impedance in Parallel Operation of Multiple Conext CL String Inverters

## Grounding System Design for Decentralized PV systems

### General Understanding of Grounding

The following notes are from Section 6: System Grounding by Bill Brown, P.E., Square D Engineering services

The National Electrical Code [1] does place constraints on system grounding. While this guide is not intended to be a definitive guide to all NEC requirements, several points from the NEC must be mentioned and are based on the basic principles of 3-phase system grounding

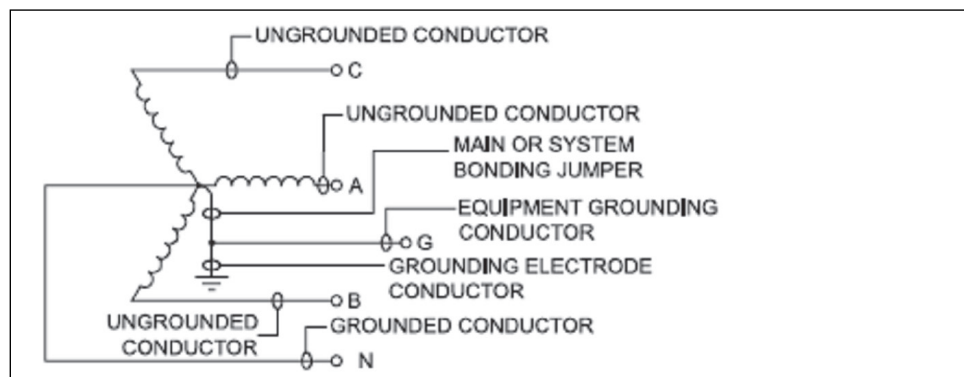

Several key design constraints for grounding systems from the NEC [1] are as follows. These are paraphrased from the code text (Note: This guide is not intended as a substitute for familiarity with the NEC, nor is it intended as an authoritative interpretation of every aspect of the NEC articles mentioned.):

- Electrical systems that are grounded must be grounded in such a manner as to limit the voltage imposed by lightning, line surges, or unintentional contact with higher voltage lines and that will stabilize the voltage to earth during normal operation [Article 250.4(A)(1)]. In other words, if a system is considered solidly grounded the ground impedance must be low.
- If the system neutral carries current, it must be solidly grounded [Article 250.20(B)]. This is indicative of single-phase loading and is typical for a 4-wire wye or center-tapped 4-wire delta system.
- For solidly-grounded systems, an un-spliced main bonding jumper must be used to connect the equipment grounding conductor(s) and the service disconnect enclosure to the grounded conductor within the enclosure for each utility service disconnect [Article 250.24(B)].
- For solidly-grounded systems, an un-spliced system bonding jumper must be used to connect the equipment grounding conductor of a separately derived system to the grounded conductor. This connection must be made at any single point on the separately derived system from the source to the first system disconnecting means or overcurrent device [250.30(A)(1)]
- Ground fault protection of equipment must be provided for solidly grounded wye electrical services, feeder disconnects on solidly-grounded wye systems, and building or structure disconnects on solidly-grounded wye systems under the following conditions:

- The voltage is greater than 150 V to ground, but does not exceed 1000 V phase-to-phase.
- The utility service, feeder, or building or structure disconnect is rated 1000 A or more.
- The disconnect in question does not supply a fire pump or continuous industrial process.  
[Articles 215.10, 230.95, 240.13].
- All electrical equipment, wiring, and other electrically conductive material must be installed in a manner that creates a permanent, low-impedance path facilitating the operation of the overcurrent device. This circuit must be able to safely carry the ground fault current imposed on it. [Article 250.4(A)(5)]. The intent of this requirement is to allow ground fault current magnitudes to be sufficient for the ground fault protection/detection to detect (and for ground fault protection to clear) the fault, and for a ground fault not to cause damage to the grounding system.

**NEC rules to consider Effective grounding solution design**

- High-impedance grounded systems may be utilized on AC systems of 480-1000 V where:
  - Conditions of maintenance and supervision ensure that only qualified persons access the installation.
  - Continuity of power is required.
  - Ground detectors are installed on the system.
  - Line-to-neutral loads are not served.
- Zig-zag grounding transformers must not be installed on the load side of any system grounding connection [Article 450.5].
- When a grounding transformer is used to provide the grounding for a 3 phase 3 wire system, the grounding transformer must not be provided with overcurrent protection independent of the main switch and common-trip overcurrent protection for the 3 phase, 3 wire system [Article 450.5 (A) (1)]. An overcurrent sensing device must be provided that will cause the main switch or common-trip overcurrent protection to open if the load on the grounding transformer exceeds 125% of its continuous current rating [Article 450.5 (A) (2)].

Again, these points are not intended to be an all-inclusive reference for NEC grounding requirements. They do, however, summarize many of the major requirements. When in doubt, consult the NEC.

The different grounding schemes (often referred to as the type of power system or system grounding arrangements) described characterize the method of grounding the installation downstream of the secondary winding of a MV/LV transformer and the means used for grounding the exposed conductive-parts of the LV installation supplied from it.

The choice of these methods governs the measures necessary for protection against indirect-contact hazards.

The grounding system qualifies three originally independent choices made by the designer of an electrical distribution system or installation:

- The type of connection of the electrical system (that is generally of the neutral conductor) and of the exposed parts to earth electrode(s)
- A separate protective conductor or protective conductor and neutral conductor being a single conductor
- The use of earth fault protection of overcurrent protective switchgear, which clear only relatively high fault currents, or the use of additional relays able to detect and clear small insulation fault currents to earth

In practice, these choices have been grouped and standardized as explained below.

Each of these choices provides standardized grounding systems with three advantages and drawbacks:

- Connection of the exposed conductive parts of the equipment and of the neutral conductor to the PE conductor results in equipotentiality and lower over voltages but increases earth fault currents.
- A separate protective conductor is costly even if it has a small cross-sectional area but it is much more unlikely to be polluted by voltage drops and harmonics, etc. than a neutral conductor is. Leakage currents are also avoided in extraneous conductive parts.
- Installation of residual current protective relays or insulation monitoring devices are much more sensitive and permit, in many circumstances, clearing faults before heavy damage occurs (motors, fires, electrocution). The protection offered is also independent with respect to changes in an existing installation.

Example of grounding circuit connections for a decentralized PV design.

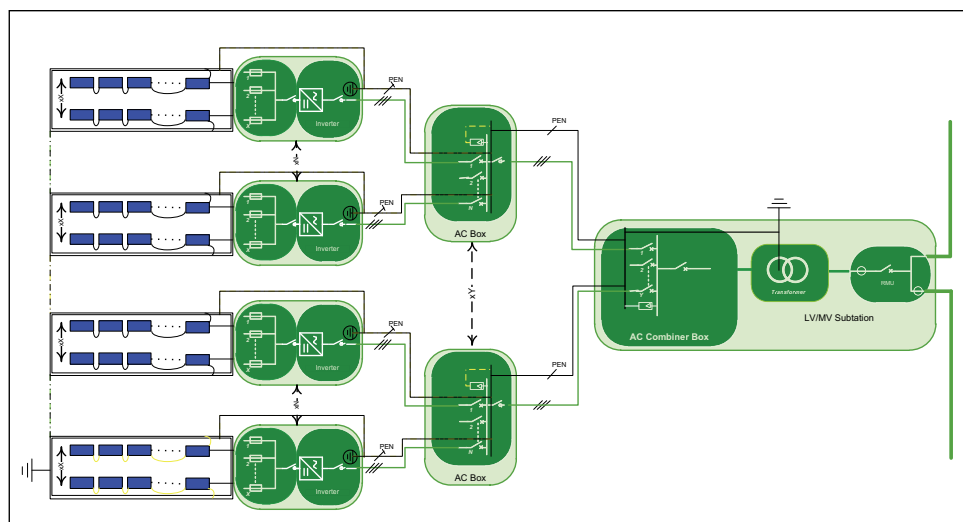

Figure 5-1 Grounding circuit connections

Sizing of the grounding conductor should follow country and area installation codes for grounding PV systems. Selection of system components like SPDs, MCCB and MCB, Disconnect switches, Panel enclosures and cables should be in accordance with the type of grounding system followed by the utility and installed type of transformer. Typical practices followed by local area safety council and fire-fighting departments should be taken into consideration when designing the PV system grounding scheme.

## Transformer selection for decentralized PV plants with Conext CL

Transformers for PV application are designed with respect to the size of the AC block. We recommend multiplication of 2500kVA block for large MW scale plants. For commercial and small utility plants that need to connect to the Utility POC at medium voltage level can be ranged anywhere between 250kW to 2500kW.

Some features a transformer for PV system could be,

- A shield is recommended as a  $dU/dt$  filter between the low voltage and high voltage windings.
- LV-MV impedance  $Z$  (%) for the transformer must be within 5% to 6%; nominally 6%. In the case of multiple LV windings,  $Z$  (%) refers to a simultaneous short circuit on all LV terminals.

The configuration of the MV transformer should take into account the local grid frequency and should meet local and regional standards.

For multiple Inverters connected on one transformer secondary winding, the low voltage (inverter-side) windings of the MV transformer can only be configured as floating Wye (Dy11). If the MV side of the system is grounded Wye, use of a floating Wye on the inverter side may not be allowed by the local utility. Make sure you understand your system configuration and the utility's rules before installation.

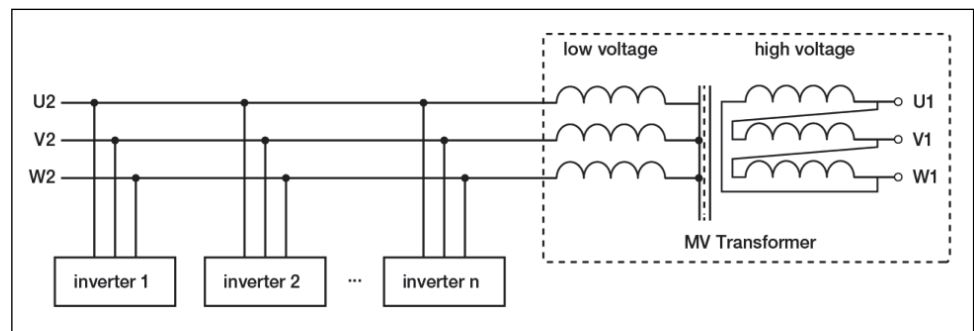

**Figure 5-2** Multiple inverter parallel connection to a transformer secondary winding

The following standard sizes of transformers are listed under IEC, and the table indicates generalized power-loss values for transformer ratings and impedance.

**Table 5-1** Power loss values for transformer ratings and impedance<sup>a</sup>

		Load losses				No load losses				
Ucc	Sn	Dk	Ck	Bk	Ak	E0	D0	C0	B0	A0
4%	250 kVA	4200 W	3250 W	2750 W	2350 W	650 W	530 W	425 W	360 W	300 W
	500 kVA	7200 W	5500 W	4600 W	3900 W	1100 W	880 W	720 W	610 W	510 W
6%	1000 kVA	13000 W	10500 W	9000 W	7600 W	1700 W	1400 W	1100 W	940 W	770 W
	1250 kVA	16000 W	13500 W	11000 W	9500 W	2100 W	1750 W	1350 W	1150 W	950 W
	2000 kVA	26000 W	21000 W	18000 W	15000 W	3100 W	2700 W	2100 W	1800 W	1450 W
	2500 kVA	32000 W	26500 W	22000 W	18500 W	3500 W	3200 W	2500 W	2150 W	1750 W

a. According to EU regulation 548/2014 – Ecodesign

For multi MW PV systems, we recommend to parallel 20 Conext CL inverters to each transformer. This defines the size of block to 2500kVA for 125kW. It's advisable to use lower impedance and an oversized transformer for smooth parallel operation of Inverters. It's recommended to use the standards size of transformer available in market to avoid long manufacturing time and higher market prices.

Schneider Electric offers high efficiency oil immersed transformer for photovoltaic systems up to 2500kVA and 35kV, 60 Hz.

## Monitoring System Design

Conext CL125 Inverters offer the option to connect over Modbus RS485 or Ethernet. Two ports (RJ45) for each Modbus RTU and Modbus TCP are provided. Any third-party data logger could be configured to connect with the Inverter and use the data logged by the Inverter to display over a monitoring portal. Conext CL125 Inverters offer standard Sunspec Modbus protocol for connectivity with third-party devices.

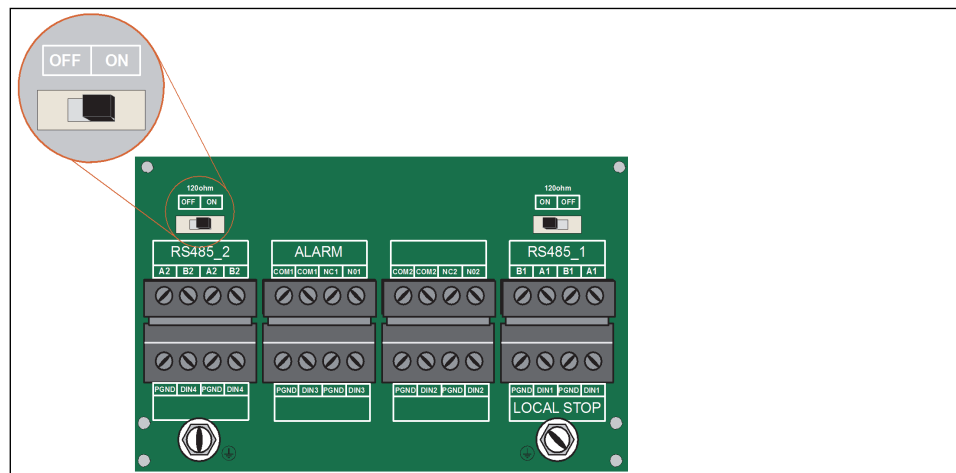

**Figure 5-3** CL125A communication port and termination resistor details

For designing the communication architecture, we recommend keeping the length of Modbus RS485 loop within 1000m (length from monitoring data-logger to the last inverter).

Generally, third-party data-loggers specify the limits of the total number of inverters connected over a daisy chain (mostly up to 32), but this is an important parameter to know while designing the communication circuit for Conext CL125 Inverters.

Third-party monitoring solutions such as Solar-Log™, Also Energy, and Enerwise™ are pre-tested and qualified for plug and play.

**For more information visit:**

Solar-Log: [www.solar-log.com](http://www.solar-log.com)

Also Energy: [www.alsoenergy.com](http://www.alsoenergy.com)

Enerwise: [www.enerwise.asia](http://www.enerwise.asia)

## Grid Connection

The connection of the PV plant to the utility grid terminates at the point of common coupling (PCC). Schneider Electric provides a Grid Box solution for achieving utility requirements at the PCC. Generally, Grid box mostly consists of the following components:

- An MV switchgear of rated grid voltage, current and fault current breaking capacity
- Tariff metering for Utility and Check Metering for PV plant owner
- PV plant controller
- A supervisory, Control and Data Acquisition system for the PV plant (if required by either the utility or the client)
- PV plant service transformer
- AC power distribution box
- Communication center for SCADA systems and PV plant security (optional)
- Main weather station of PV plant

Depending on the equipment and system, the size and quantity of the Grid box could change.

Along with basic monitoring capability, Schneider Electric offers advanced, state-of-the-art PV plant SCADA systems with Conext control monitoring platform as requested by client.

Contact Schneider Electric for further information about configuring SCADA systems, PV plant communication and Grid controller offers.

## Role of Circuit Impedance in Parallel Operation of Multiple Conext CL String Inverters

Multiple string inverters are paralleled in decentralized PV power plants. These inverters are connected to MV grid using a three-phase transformer. Transformer leakage impedance, Cable impedance and Grid impedance constrain the number of inverters that can be paralleled. Interaction between the AC network grid and distributed PV Inverters (DG – Distributed Generators) may generate instabilities due to the overall system low frequencies resonance, and it is recommended to avoid high impedance grids (weak grids).

Figure 5-4 below illustrates a general single line diagram, AC grid-connected Conext CL string inverters (DG(1)...DG(n)) through two transformer stages. The PV power plants are usually galvanically separated from the transmission system (table I) by the following two transformation stages:

- Low-to-medium voltage transformer (Tx.LV-MV)
- Medium-to-high voltage transformer (Tx.MV-HV)



The PV power plant system stability is influenced by the total equivalent impedance defined as follows with the recommendable limits:

- $Z_{cLV}$  - LV interconnection line impedance <1% p.u.
- $Z_{TxLV.MV}$  - LV to MV transformer impedance <6% p.u.
- $Z_{TxMV.HV}$  - MV to HV transformer impedance <6% p.u.
- $Z_{cHV}$  - HV interconnection line impedance <1% p.u.
- $Z_{total} = Z_{cLV} + Z_{TxLV.MV} + Z_{cMV.HV} + Z_{TxMV.HV} + Z_{cHV}$

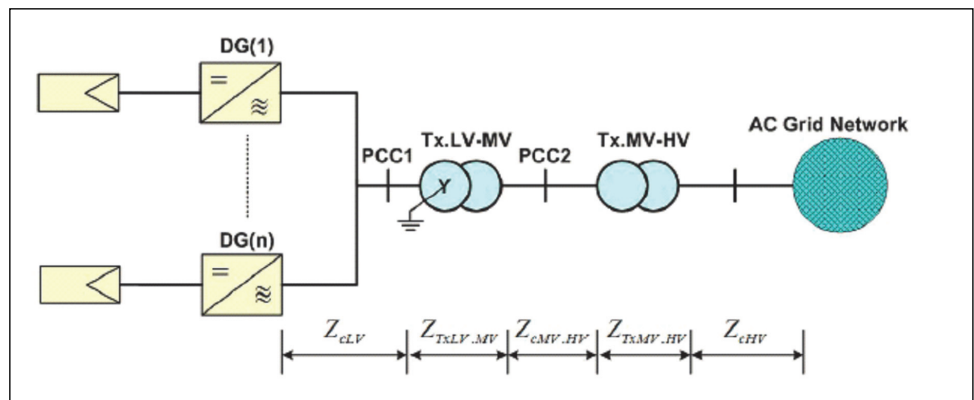

**Figure 5-4** Generic AC grid connected inverters diagram

For smooth, reliable and continuous parallel operation of Conext CL string inverters, it is important to follow the following recommendations from Schneider Electric.

- Restrict the AC cable impedance up to 3% of  $U_n$ .
- Restrict the Transformer impedance (between LV and HV winding) up to 6%. We do not recommend an AC block size of more than 2500kVA for Conext CL125A inverters.
- If a three-winding transformer is used (HV-LV-LV), including the previous point, also maintain the short circuit impedance of minimum or greater than 10% between each LV winding.
- Oversize (by 5-10%) the transformer kVA capacity with respect to installed inverter kW capacity.
- AC cable sizing calculation should also consider the reactive impedance of cables and not just resistive. Grid impedance is an important parameter for this consideration.
- Calculate the grid impedance at PCC before designing the overall PV plant circuit. Short circuit power should be least 8 times higher than the plant installed power:  $S_{sc,pcc} > 8 \times S_{plant}$



# 6

## Layout Optimization

This chapter on layout optimization contains the following information:

- Layout Design Rules

## Layout Design Rules

### **DANGER**

#### **ELECTRICAL SHOCK AND FIRE HAZARD**

Installation including wiring must be done by qualified personnel to ensure compliance with all applicable installation and electrical codes including relevant local, regional, and national regulations. Installation instructions are not covered in this Solution Guide but are included in the relevant product manuals for the Conext CL125 Inverter. Those instructions are provided for use by qualified installers only.

**Failure to follow these instructions will result in death or serious injury.**

As a recommendation, the following layouts can be used to design standard blocks using Conext CL125 Inverters.

- Selection of structural design should be based on the string length and number of strings connected to each inverter.
- Arrangement of Modules on PV racking should be decided in-line with length of string to reduce DC string cable route length.
- In case of single axis trackers, this requirement becomes more stringent from both inverters and tracker's perspective.
- Location of inverter should be decided prior to defining the block size.
- Connection of strings to Inverter and use of DC array combiner will be dependent on location of the string inverter.
- Location of AC array combiner box and LV-MV station should be selected in line with block size, to divide blocks and reduce cable length from AC combiners to LV-MV station.
- In most cases, the standard defined block should be multiplied to avoid several wiring mistakes and shorten installation time.

# 7

## Frequently Asked Questions (FAQ)

This chapter of FAQs contains answers to general questions that may arise when considering Conext CL125 Inverters in designing a power system.

## Safety Information

### **DANGER**

#### **ELECTRICAL SHOCK AND FIRE HAZARD**

Installation including wiring must be done by qualified personnel to ensure compliance with all applicable installation and electrical codes including relevant local, regional, and national regulations. Installation instructions are not covered in this Solution Guide but are included in the relevant product manuals for the Conext CL125 Inverter. Those instructions are provided for use by qualified installers only.

**Failure to follow these instructions will result in death or serious injury.**

## Frequently Asked Questions

1. Can we install third party components inside the wiring compartment within the inverter?  
No. Components installed inside the wiring compartment within the inverter are tested in the factory before dispatch and hold warranty for the product. If any external component is installed inside the wiring compartment, that may void warranty.
2. What type of Transformer can be connected with Conext CL125 Inverters?  
Dy1 Dy11, Dd0 type transformers should be connected with Conext CL inverter. LV voltage of transformer should match the inverter's AC output voltage and MV voltage should match the grid connection voltage. CL125 Inverters can also connect to Delta type networks. Choose the transformer based on the utility network requirements
3. What is the solution if my AC cable size is higher than the terminal size of Conext CL inverter?  
An external AC terminal box has to be used in certain situations. This box will have input from the inverter with the maximum cable size the inverter terminal can fit (185 mm<sup>2</sup> / 350kcmil). And, the output terminal of this AC box can have higher sized cables as required by design.
4. Do I need assistance from Schneider Electric for first installation of Conext CL inverters?  
No. For first installation, follow Schneider Electric's installation manual for the Conext CL inverter. Get yourself familiarized with possible hazardous situations, follow recommended installation practices, and use a certified installer. In case of any difficulty, you can contact Schneider Electric for assistance.
5. Do I need to contact Schneider Electric at the time of designing PV system configuration for proposal?  
We recommend that Installers / Developers contact Schneider Electric when they start considering the use of Conext CL inverters. This way we can help you to design the most reliable and cost competitive solution with no technical surprises during installation.

6. How can I update the firmware version of Conext CL inverter?  
 Conext CL inverter firmware is available at <http://solar.schneider-electric.com/product/conext-cl-125-string-inverter/>. You can download the latest firmware and upload it using the Conext CL EasyConfig Tool installed on your computer. Every time the Conext CL inverter is installed, the installer should use the latest firmware version available on the website.
7. Where can I find the Conext CL OND file for PVsyst simulation?  
 You can find it at <http://solar.schneider-electric.com/product/conext-cl-125-string-inverter/>
8. Is there any tool from Schneider Electric to help my sizing the strings for my installation?  
 No. The Schneider Electric Sales Application Engineers can help Schneider Electric clients to size correct strings, or a third-party software, such as PVsyst could be used to size strings.
9. Is measurement of power inside the Conext CL inverter good enough for tariff metering?  
 Measurement of power inside the Conext CL inverter takes place with built-in sensors. Accuracy of current and voltage sensors within CL125A inverters measures within 0.5% error. Generally tariff metering has stringent requirements for accuracy and other compliance related to utility. User must discuss this requirement in detail with the utility company.
10. Where can I find an Installation manual for Conext CL inverters?  
 Installation manual for Conext CL inverter can be found at <http://solar.schneider-electric.com/product/conext-cl-125-string-inverter/>
11. What is the Schneider Electric customer care contact detail for technical support?  
 Customer care contact details in your respective region are found at <http://solar.schneider-electric.com/tech-support/>
12. Does Schneider Electric provide Engineering, Procurement, Installation and Commissioning services for PV systems?  
 Yes. Contact us for more details and discussion for our services.
13. Which other system components can Schneider Electric offer?  
 Follow the chart provided under the topic "Building blocks of Decentralize PV system" in this document to check the offers from Schneider Electric.
14. What is the maximum oversizing that I can achieve for Conext CL inverters?  
 We recommend 20% to 30% oversizing. It can be more depending on the climatic conditions. Maximum oversizing for the CL Inverter could be up to 50% (1.5 DC-AC ratio). If more than 50% oversizing is required, contact your local Sales Application Engineer for technical assessment of string sizing. In any case, the limits of short circuit current for the inverter should not be violated.

15. How is a choice of transformer affected by the inverter's operating capability?

The inverter's operational capability depends on the Transformer in two ways:

- Parallel operation of inverter: The inverter's parallel operation is a function of short circuit impedance ( $Z\%$ ) and the transformer is a circuit component with a very large impedance portion of the overall circuit. We recommend keeping the Impedance of the transformer as low as possible.
- The Conext CL inverter supports 3 phase 3 wire WYE and 3 wire DELTA wiring schemes. When the Transformer is selected, it is important to match Utility side winding requirement as per Point of connection and Low voltage side winding requirement as per the inverter's operational compatibility.

16. What is the limit of power factor Conext CL inverters are capable of?

Conext CL can operate within 0.8 lead and 0.8 lag power factor limit.

17. Does Conext CL inverter support LVRT requirement?

Yes. It does. LVRT requirement is specified in respective PV grid code of country. Conext CL inverter firmware is programmed to follow the LVRT requirement (curve) during certification of each country. Contact us to know the list of countries Conext CL inverters are certified for.

18. Do I need to have PSS/E model of Conext CL inverter? Can Schneider Electric provide it?

Yes. Schneider Electric can provide a generic or user defined CL125A Inverter PSSE model file. This requirement is generally requested by Utilities to include the model of your power plant into their power system. We recommend that clients discuss this type of requirement with the utility well ahead (during the system planning stage) and choose the right wiring scheme and metering scheme. A billable PSSE model can be created based on client's request. If you have such a requirement, contact us for further discussion.

19. What type of support I can have from Schneider Electric for designing configuration of my PV system?

Schneider Electric provides ready reference documentation for designing the system, for example, the Solutions guide, Owner's guide, training material, etc. If you need any additional information or services, contact us for more discussion.

20. Which parameters do I have to confirm and use to order Conext CL inverters?

Unlike centralized inverters, Conext CL string inverters are simple to configure and install. Since it is simple, there isn't any technical information sheet required to buy these inverters. Schneider Electric's sales representatives will help customer buy the right type of inverter and associated wiring box. This solutions guide can be used to select the right wiring box.



21. When does the temperature de-rating begin for Conext CL inverter? How much does it de-rate?

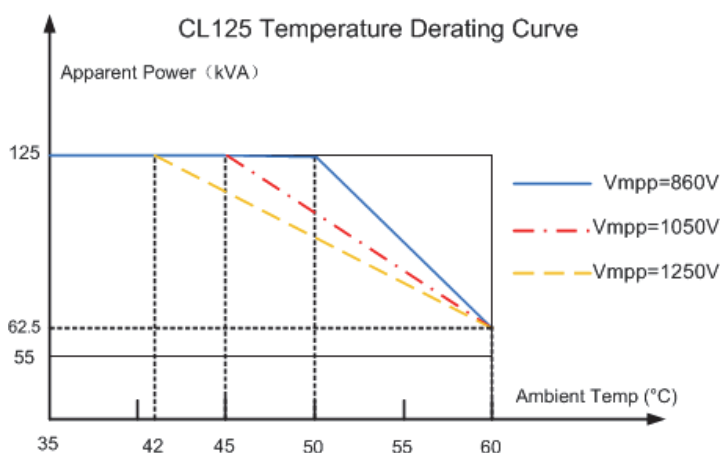

22. What if I install the Conext CL inverter in outdoor place?  
Conext CL inverter is rated for outdoor duty. It can be installed as per instructions provided in Installation Manual. For more information about outdoor installation, see the Installation manual.
23. What is the normal manufacturing time after confirmation of order for Conext CL inverters?  
Generally it takes 10 to 14 weeks to manufacture CL Inverters. We recommend clients consider this time along with shipping time to plan their project. If there is a steeper timeline, contact us for further discussion.
24. Where can I find the certificates for Conext CL inverter?  
CL inverter certifications are available at  
<http://solar.schneider-electric.com/product/conext-cl-125-string-inverter/>
25. What type of warranty does Schneider Electric offer for Conext CL inverters?  
Warranty terms for Conext CL depends on the region of installation. Users can find the information about warranty at  
<http://solar.schneider-electric.com/product/conext-cl-125-string-inverter/>
26. Do I need to oversize the transformer when I connect to multiple Conext CL inverters?  
We recommend equal or oversized transformer for Conext CL inverters. Especially when there is large number of CL inverters connected in parallel to one transformer low voltage winding, we recommend to oversize the transformer by 10%.
27. What type of wiring schemes can Conext CL inverter be connected with?  
The Conext CL inverter can be connected with 600V, 3 Phase wire WYE, or 3 wire DELTA wiring schemes.
28. How much space do I need to install Conext CL inverters side by side?

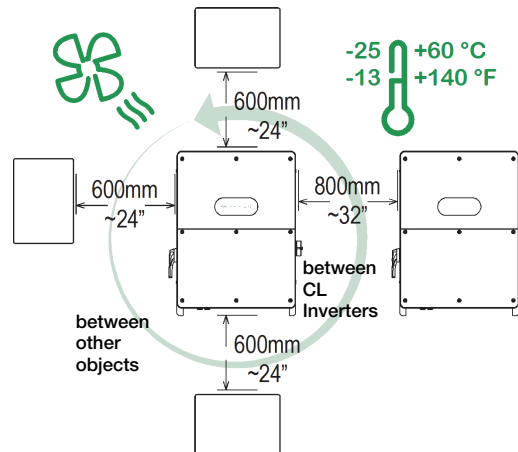

29. If any component inside the Conext CL inverter is damaged during installation how can I buy a new component?  
 Contact your Schneider sales representative to buy the components.
30. What type of monitoring system I can use with Conext CL inverters?  
 The Conext CL inverter is compatible with all major third-party monitoring solutions. To plan your monitoring solution in advance, contact your Schneider Electric sales representative and the third-party monitoring solution provider.
31. Is it mandatory to use an AC circuit breaker at the output of Conext CL wiring compartment?  
 We recommend that installer / client uses the circuit breaker to support AC surge protection device.
32. What is the brief specification of DC and AC Surge protection devices provided in the wiring compartment of Conext CL inverters?  
 Conext CL wiring compartments are equipped with Type 2 DC and Type 2 AC surge protection devices.
  - DC SPD make: CITEL, Type 2
  - AC SPD: Type 2, PCB mounted
33. What is the brief specification of DC disconnect switch provided in the Conext CL wiring compartment?  
 A Conext CL inverter is equipped with a 1500 V, 250 A DC Disconnect switch.
34. Is there an Anti-Islanding protection provided in the Conext CL inverter?  
 Yes. The Conext CL inverter is equipped with anti-islanding protection.
35. What is the output operating voltage range capability/limits, response to network voltage sags?  
 The inverter will deliver full power at unity power factor with +15% grid voltage variation.

36. What is the wake up value and power watt for Conext CL inverters?  
 Wakeup voltage - 920 VDC at AC nominal voltage of 600VAC.

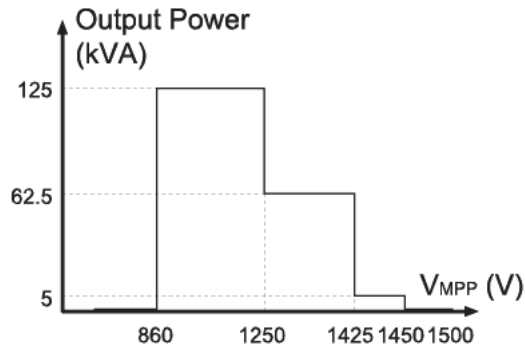

The minimum start up power is 380 watts (Under normal Grid voltage, and PV voltage).

37. What is the latency to set the output of the inverter to 0% from 100%?  
 Two seconds (typical).
38. What is the latency to set the output of the inverter to 100% from 1%?  
 ~500 ms.
39. Can we control the output of the inverter in 1% steps? What is the time resolution?  
 1% steps is possible and time latency is ~500 ms.
40. How long does it take for a firmware upgrade over RS485 or eConfigure CL125 APP for a single inverter?  
 10 to 15 minutes (approximately)
41. What is the value of the inverter's impedance?  
 Calculation of the impedance at 175 Hz (R and X)  
 $R + Xj = 0.006 - 22.7j$   
 Resistance = 0.006  
 Reactance = -22.7j
42. Can we remotely reset (on or off) the inverter over Modbus?  
 Yes.

43. Explain a detailed DC Voltage vs. power curve for operating, de-rated and off conditions with respect to specific voltage or range or voltage.

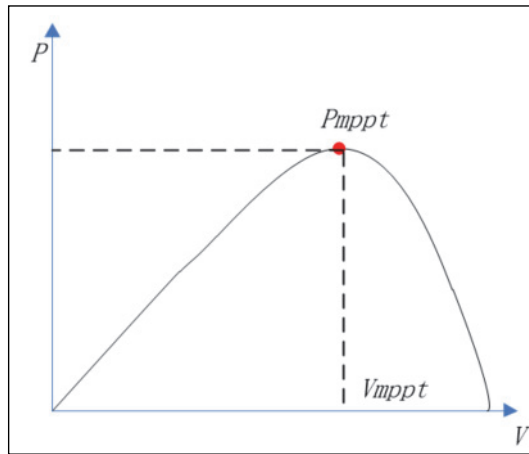

MPPT voltage range: 860 ~ 1450V

Full MPPT voltage range: 860 ~ 1250V

Maximum voltage: 1500V

Starting voltage: 920V

When the PV voltage is greater than 920V, the inverter began trying to connect to the grid, according to the MPPT tracking algorithm, the input voltage moves to the left step by step, eventually stabilizing in maximum power point.

When a derating event occurs, the input voltage from the maximum power point moves to the right, the input voltage is raised gradually decrease the power to achieve derating. When the inverter is insufficient light in the evening, if the input power is less than 80w, the inverter will off the grid, stop running.

44. What type and size of cable could be connected to the output of CL125 Inverters?

Type	Terminals	Terminal type	Maximum cable aluminum			Maximum cable copper		
			stranded	Solid		stranded	Solid	
				Round	Sector		Round	Sector
CL125A	L1 L2 L3 PE	Screw	185mm <sup>2</sup> /350kcmil	185mm <sup>2</sup> /350kcmil	185mm <sup>2</sup> /350kcmil	185mm <sup>2</sup> /350kcmil	185mm <sup>2</sup> /350kcmil	185mm <sup>2</sup> /350kcmil

45. What's the switching frequency?

The switching frequency is 16 kHz.

46. What's the self-consumption power of the CL Inverter?

<b>CL Inverter power consumption information</b>	<b>Power Consumption</b>
Self-consumption during operation (Excluding IGBT and fans)	70W
Self-consumption during operation (including IGBT and fans)	2450W
Consumption at night (Unit remain disconnected from grid)	<8W
Minimum power to start	380W

47. What is the CL Inverter's de-rating with respect to AC output voltage?

When AC voltage increases, it won't result in derating, just power limitation because for the same power, current decreases. Only when AC voltage is decreasing, power decreases because after current reaches the rated maximum current, it can't be increased. At the same time, the inverter won't display "derating" if the power decrease is due to a grid voltage decrease.

Vmin=480V: S=80 kVA

Vnom=600V: S=125 kVA

Vmax=690V: S=125 kVA

48. Does the inverter store any data? How much and what data is stored?

The inverter stores preservation machine operation and fault information;

1. operation information 5 minutes recording a record 30 days
2. recent fault information recording 100.
3. recently recorded event information 100
4. monthly and annual energy production (power curve (7 days), generating capacity (about 365 days), monthly energy output (180 months), the generating capacity (30 years))





## Schneider Electric

[solar.schneider-electric.com](http://solar.schneider-electric.com)

As standards, specifications, and designs change from time to time, please ask for confirmation of the information given in this publication.

© 2018 Schneider Electric. All rights reserved.

975-0798-01-01 Revision A

Printed in